

MULTIFUNCTION TRANSMITTER

PD 1652

Manual

Contents

1.	General	1
1.1.	Functions	1
1.2.	Block diagram of PD 1652	2
1.3.	Connection to P-NET	2
1.4.	Channels/registers	3
1.5.	Combining Channels	6
2.	Analog Input Channels	7
2.1.	Block diagram of Analog Input Channels	7
2.2.	Registers on analog input channel (channel 1-2)	8
2.2.1.	Description of error codes on channel 1 and 2	10
2.3.	Connection to analog input channels	11
2.3.1.	Temperature measurements	11
2.3.2.	Current measurement, 0-20 or 4-20 mA	11
2.3.3.	Voltage measurement, 0-500 mV	13
3.	Conductivity Inputs	14
3.1.	Block Diagram of Conductivity Channels	14
3.2.	Registers on conductivity channel (channel 3-4)	15
3.3.	Temperature compensated measurement	18
3.4.	Measuring the SUM and difference	19
3.5.	Conductivity measurement with one electrode	20
3.6.	Conductivity measurement with two electrodes	20
4.	Current Output	21
4.1.	Current Output, Electrical	25
5.	PID Regulator	27
5.1.	Calculation of Actual Value	32
5.2.	Example of simple regulation	34
5.3.	Example of sequence regulation	36
5.4.	Example of pressure difference regulation	38
5.5.	Example of scaling by means of PID regulator	40
5.6.	Example of proportional regulation	41
6.	Limit Switch / Batching Channel	43
6.1.	Limit Switch, function	47
6.1.1.	Limit Switch, example	47
6.1.2.	Limit Switch with positive offset values, example	48
6.2.	Batch run	49
7.	Input Channels, measuring of frequency	51
8.	Simple input channels	56
8.1.	Detection of switch state, e.g. push-buttons, microswitches	57
9.	Digital Output	58
9.1.	Registers on Digital Output Channel	59
9.2.	Output control via P-net	65
9.3.	Output controlled via timer, (pulse output)	66
9.4.	Sequence control	66
9.5.	Single feedback (TBM) with variable delay	67
9.6.	Double feed-back signal with variable delay	69
9.7.	Feedbacks	70
9.8.	Controlling of Control-flag	71

9.9.	Duty cycle regulation	71
9.9.1.	Duty cycle output in one direction	71
9.9.2.	Duty cycle regulation in two directions	72
10.	Service Channel (Channel 0)	73
11.	Display Channel (Channel E)	78
11.1.	An example of programming a display channel via the PD 230 display unit	80
11.2.	Programming of the function keys (K1-K8)	81
11.3.	Displaying error codes	82
11.4.	Connecting the PD 230	82
11.5.	Assembly drawing, PD 230	83
12.	Voltage Output	84
13.	Construction, Mechanical	85
13.1.	Connections	86
14.	Specifications	87
15.	Noise limiter	89
16.	Survey of registers in the PD 1652 module	90
17.	Survey of standard identifiers in the PD 1652 module for use in Process-Pascal	91
17.1.	Survey of standard identifiers (Bit)	92

1. General.

The PD 1652 Multifunction transmitter is a MODULE in Proces-Data's module series 1000. The PD 1652 module is intended for the collection and processing of signals from a weighing element. However, the module can also be used for the collection and processing of various digital signals, as well as controlling valves, relays etc. from the measurement results collected.

1.1. Functions.

- * Connection of analog measuring signals on two independent channels. The measuring signals can be voltage (0-500 mV), current (0-20 or 4-20 mA) or derived from a temperature detector Pt-100.
- * Connection of electrodes for conductivity measurement on two independent channels. The range is between 1-10000 μ S or 0.1-1000 mS.
- * An analogue current output 4-20 mA, which among other things can be used to indicate various measured results on a display instrument.
- * Internal PID-regulator, which via the analogue output or a digital output can be used for control purposes.
- * 2 internal limit channels for use as alarm detectors, or for batching from a user defined measurement and a set point.
- * 3 digital input channels, useful, for example, when controlling external equipment. Furthermore, these input channels can also be used as counters for registering pulses (max 250 Hz).
- * 2 digital output channels for controlling relays, valves etc.
- * Direct connection of the PD 230 display. Using the display unit it is possible to select various measurement results as well as setting the module for various functions.
- * Connection to PD's local network, the P-net. Using the P-net, it is possible to carry out the same functions (as the display unit) from a central computer.
- * Voltage output 24 V DC max. 150 mA. Useful to power passive digital in- and outputs or other external equipment.
- * Advanced self testing facility which can be monitored using the display unit or through the P-net.

1.2. Block diagram of PD 1652:

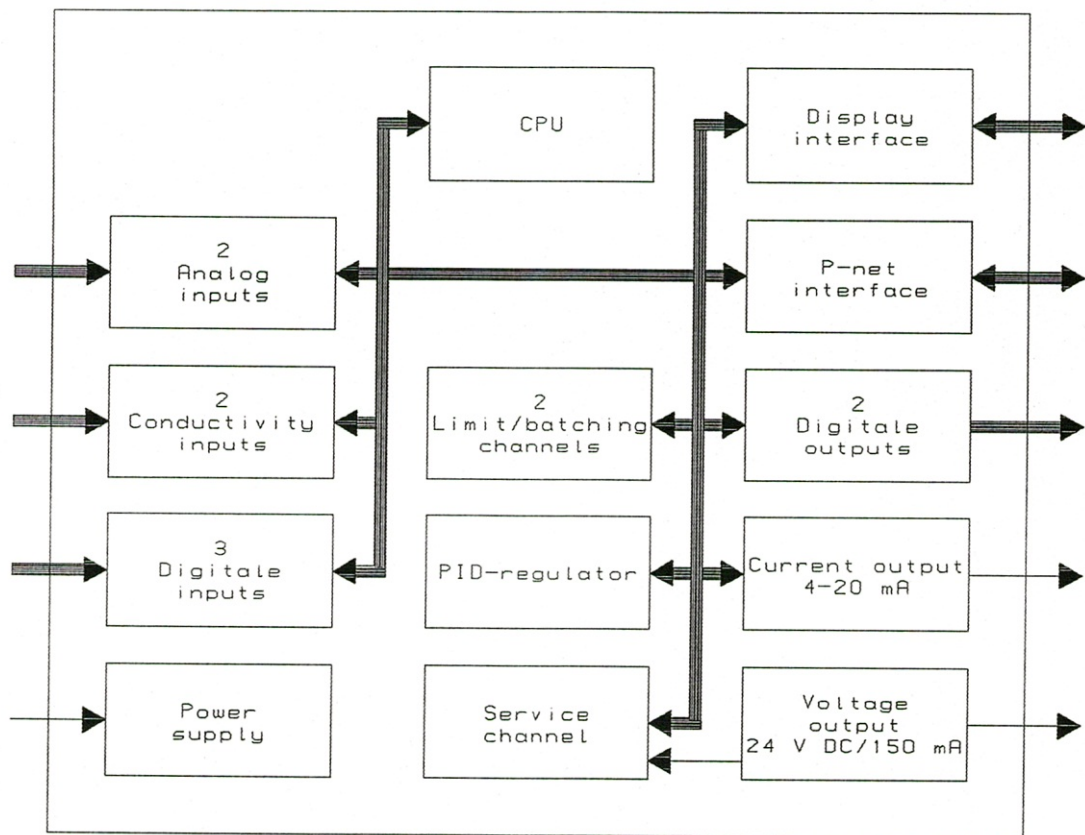

502099AD

1.3. Connection to P-NET.

The PD 1652 module can be connected to Procecs-Data's local area network P-Net, which is a local area network intended for process control and collection of data.

The PD 1652 module is controlled via the P-Net. Setting the module for the functions required, and communication between the module and a control computer is also carried out via the P-Net.

A typical application of the P-Net is that of transmitting measurements from one or more modules to a central computer and displaying the results on a screen. Furthermore, it is possible to control the outputs (digital as well as analogue) via the computer and to check modules for internal & external errors.

More information about the operation and structure of P-Net can be obtained by writing to Procecs-Data.

1.4. Channels/registers.

PD 1652 Module contains:-

1 Service channel	(channel 0)	2 Dosing channels	(channel 7-8)
2 Analog inputs	(channel 1-2)	3 Digital inputs	(channel 9-B)
2 Conductivity inputs	(channel 3-4)	2 Digital outputs	(channel C-D)
1 Current output	(channel 5)	1 Display channel	(channel E)
1 PID regulator	(channel 6)		

A set of 16 registers numbered from 0 - F, is associated with each channel (see diagram below). For addressing a register within a particular channel, a symbolic address of 2 hexadecimal digits is used.

Example: Register 4 on channel 8 needs to be addressed.

The symbolic address will then look like this:

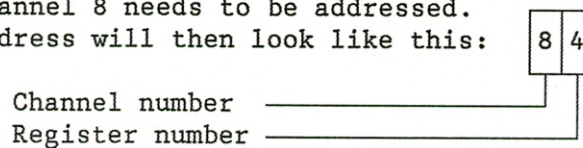

If attempting to read a non-defined register, the module will not respond. This will be indicated as an error in the P-net transmission.

A set of registers is shown in the fig. below. As an example, the registers associated with channel 0 are defined.

Throughout the manual the register sets will be visualized in a table. The example below concerns the register sets belonging to channel 0.

The register names are standard identifiers defined in Process-Pascal.

Reg.no.	Register name	Write	Storage medium	Number of bytes	Read out
0					
1	DeviceType		P	2	Decimal
2	PrgVers		P	2	Decimal
3	Error3	X	R	1	Hexadec.
4					
5					
6					
7	WDTimer	X	R	2	Decimal
8	WDPreSet	X	E	2	Decimal
9	Code9	X	E	4	Hexadec.
A					
B					
C					
D					
E					
F	ErrorF		R	1	Hexadec.

Storage media: R;RAM, E;EEPROM, P;PROM, BR;BATTERY RAM

Data stored in EEPROM is retained after a reset, or after a power failure. If this data needs to be modified, the "Program Enable" switch must be ON.

Data stored in Battery RAM is retained after a reset or a power failure.

Types of channel

The module consists of several channels which each have their own function. These channels can be combined to suit the needs of the user. The module contains channels of the following three types:

* INPUT CHANNEL

Direct electrical connection to input device. Input data is stored in a register of its own channel. Typically, it's possible to use scaling.

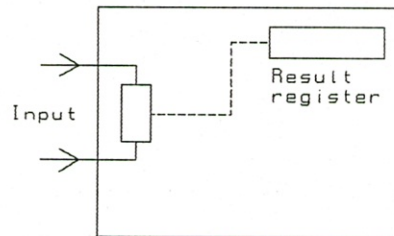

502025A1

* INTERNAL CHANNEL

Channel without electrical connection. The channel takes input data from other channels, or the contents of registers which have been set by the display unit or P-net. Input data is selected using a code register. The resultant data is stored in an associated output channel register.

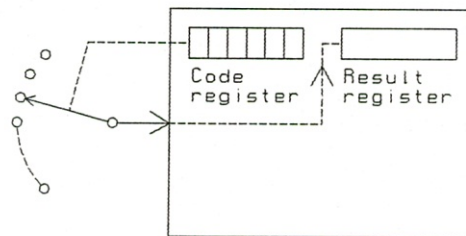

502025A1

* OUTPUT CHANNEL

Direct electrical connection to output device. The channel takes data from other channels or from registers which have been set via the display-unit or P-net. Input data is selected using a code register. Output data is stored in a register which directly controls the output device

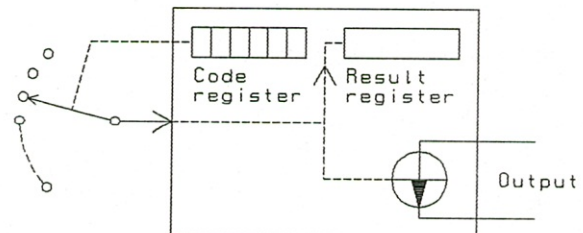

502025A1

1.5. Combining Channels.

If, for example, the current output is required to be controlled by a measured weight on the weight input channel, it can be done by pointing to the measured value on the weight channel using a code reg, in the current output channel (see fig.1.6a.).

As soon as a measured value is pointed to by the code register, the module will create an indirect register, where the measured value can be read. This means that the measurement can be read both in the result register in the analogue input channel, and in the indirect register in the current output channel.

Note: It is not possible to point to an indirect register using a code register, as this will result in an error on that channel. The indirect registers are marked with an asterisk in the definition of registers for the various channels.

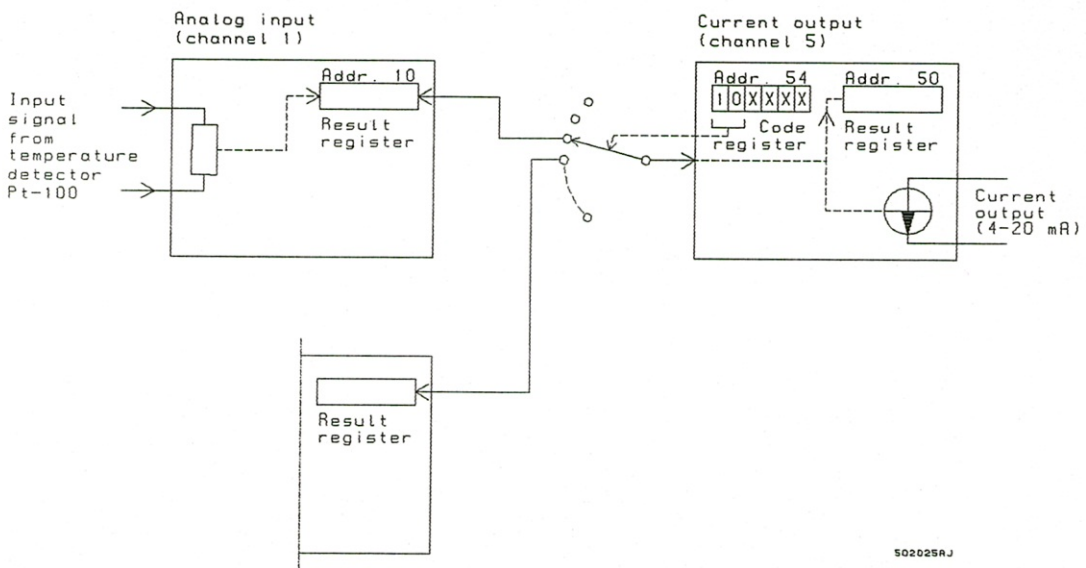
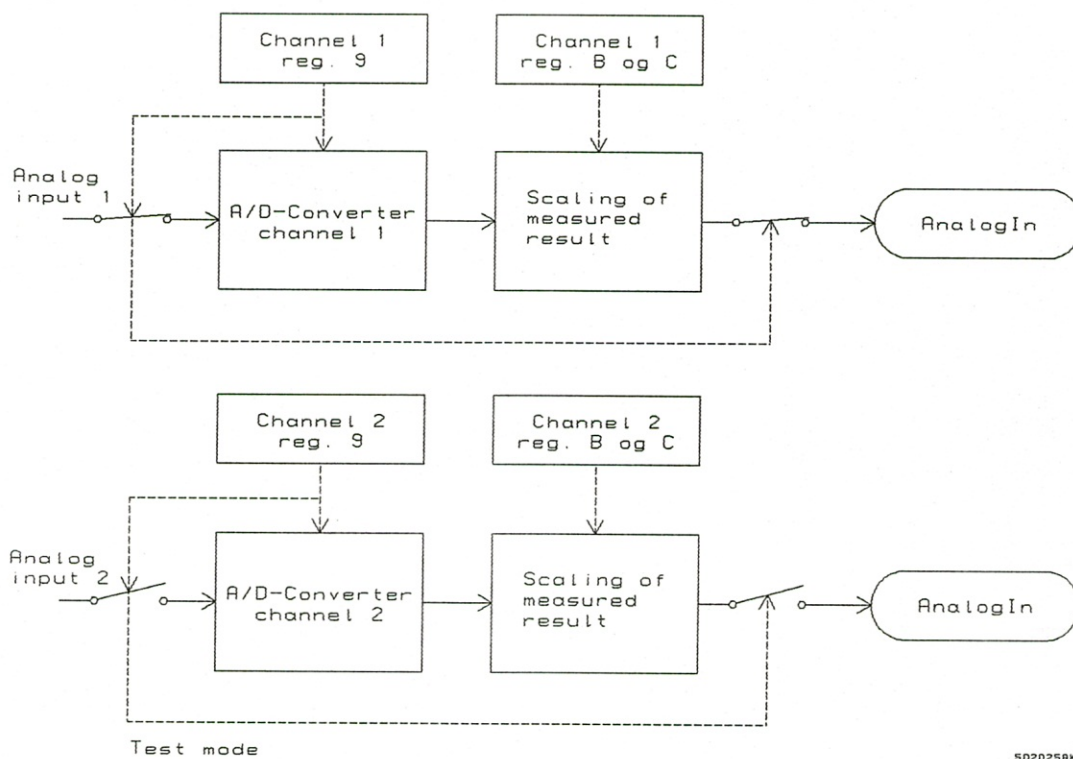

Fig. 1.5.a.

2. Analog Input Channels.

2 analog input signals can be connected to the PD 1652 module: Current (0-20 or 4-20 mA), voltage (0-500 mV) or temperature by means of a temperature detector Pt-100. The signal type is selected separately for each channel by means of a code.

2.1. Block diagram of Analog Input Channels:



2.2. Registers on analog input channel (channel 1-2).

In the two analog input channels (channel 1-2) the following registers have been defined (channel 1-2).

Reg.no.	Contents	Write	Storage medium	Number of bytes	Read out
0	AnalogIn		R	4	Decimal
1					
2					
3					
4					
5					
6					
7					
8					
9	Code9	X	E	4	Hexadec.
A	Fullscale ZeroPoint	X	E	4	Decimal
B		X	E	4	Decimal
C					
D					
E					
F	CHError		R	1	Hexadec.

* Indirect register

Reg. 0: AnalogIn.

The measurement result, being temperature, current or voltage, can be read out from register 0.

Reg. B: FullScale.

FullScale is only used with current or voltage signals. The value expected in register 0, at full signal on the analog input (20 mA / 500 mV), will be the same as the value placed in the FullScale register.

Reg. C: ZeroPoint.

Current and voltage signals, the value read in register 0 at minimum signal on the analog input (0 mA / 4 mA / 0 mV) will be the same as the value placed in the ZeroPoint register. If the module has been programmed as a Pt-100 input, ZeroPoint is used for offset-adjustments of the temperature detector.

Reg. 9: Code9.

The code consists of 6 digits each with its own meaning.

Code register for Analog input channel (Reg. 9).

- Not in use
- 0: No 3 mA alarm
- 1: 3 mA alarm limit
- 0: Normal mode
- 1: Test mode
- 0: Not in use
- 1: Temperature, Pt-100
- 2: Current, 0-20 mA
- 3: Current, 4-20 mA
- 4: Voltage, 0-500 mV

Not in use

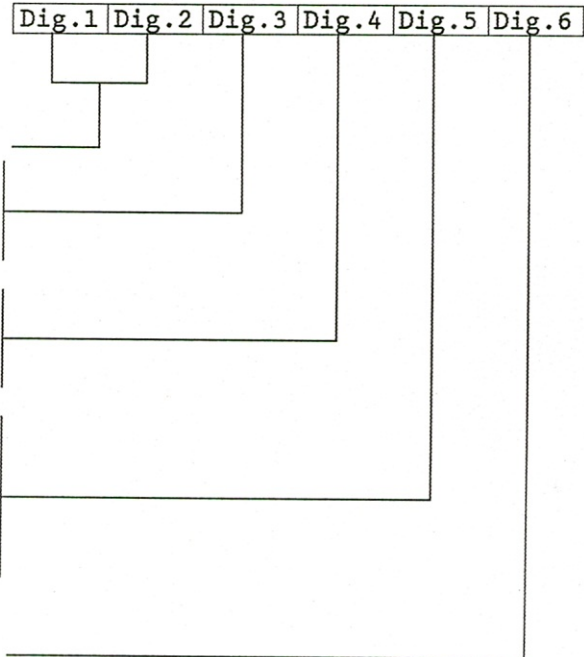

Note: If the channel is not in use, write "0" in digit 5 ("channel not in use"), otherwise errors can occur.

When current is being measured (4-20 mA), an extra function can be used (3 mA alarm limit). When this function is required, the module will generate an error as soon as the current on the input falls below 3 mA. (see register F).

When the channel is in TEST-mode, no measuring result will be calculated but it is possible for the user to insert a random value in register 0.

Reg. F: CHError.

The CHError register shows whether there is currently an error on the channel concerned, or whether there is a general error on the module which might lead to the channel being defective.

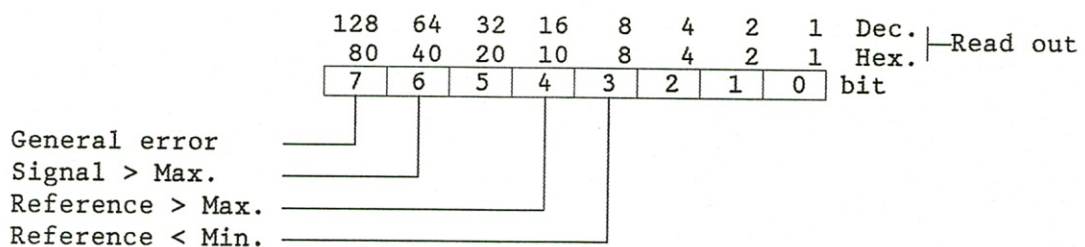

If bit 7 (General error) is set, then the other bits are insignificant, as the general error can be derived from error codes on the other channels (see Service Channel).

2.2.1. Description of error codes on channel 1 and 2.

Bit	Meaning	Type of signal	Error source
6	Signal > 400°C	Temperature	Input signal too high
5	Signal < -30°C	Temperature	Input signal too low Temp. detector short circuit
4	Int. reference > max.	Temperature	Internal fault
3	Int. reference < min.	Temperature	Temp. detector disconnected Internal fault
6	Signal > 550 mV	Voltage	Input signal too high
5		Voltage	
4	Int. reference > max.	Voltage	Internal fault
3	Int. reference < min.	Voltage	Internal fault
6	Signal > 22 mA	Current (4-20 mA)	Input signal too high
5	Signal < 3 mA	Current (4-20 mA)	Input signal too low Internal fault
4	Int. reference > max.	Current (4-20 mA)	Internal fault
3	Int. reference < min.	Current (4-20 mA)	Internal fault
6	Signal > 22 mA	Current (0-20 mA)	Input signal too high
5		Current (0-20 mA)	
4	Int. reference > max.	Current (0-20 mA)	Internal fault
3	Int. reference < min.	Current (0-20 mA)	Internal fault

2.3. Connection to analog input channels.

2.3.1. Temperature measurements.

The PD 1652 module can be connected to temperature detectors of the Pt-100 type. The detector is connected to one of the two sets of terminals marked "A-B-C-D" as shown in fig 2.3.1.a.

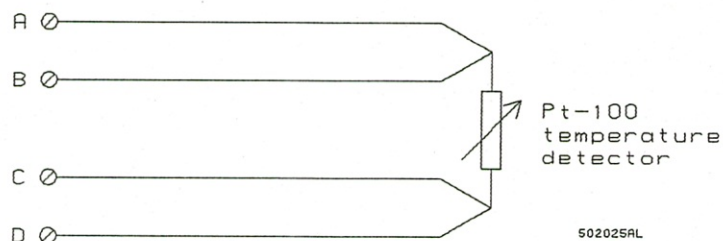

Fig 2.3.1.a.

2.3.2. Current measurement, 0-20 or 4-20 mA.

The PD 1652 module can be connected to analog current signals, 0-20 mA or 4-20 mA.

The signal is connected to one of the two sets of terminals marked "A-B-C-D" as shown in fig. 2.3.2.a.

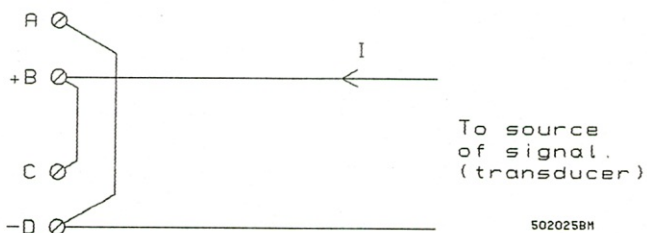
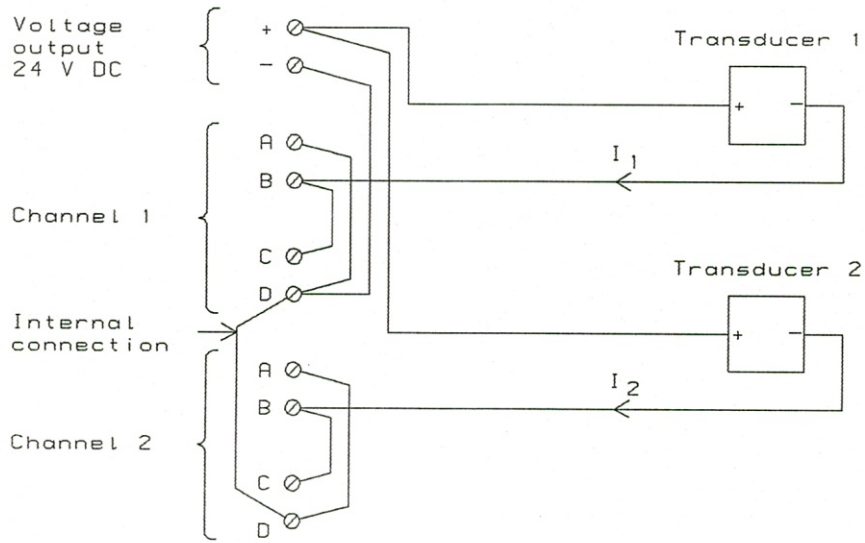

Fig 2.3.2.a.

Example of the connection of two two-wire transducers, supplied from the module's voltage output.
See fig. 2.3.2.b.



502025BN

Fig. 2.3.2.b.

2.3.3. Voltage measurement, 0-500 mV.

The PD 1652 module can be connected to analog voltage signals, 0-500 mV.

The signal is connected to one of the two sets of terminals marked "A-B-C-D" as shown in fig. 2.3.3.a.

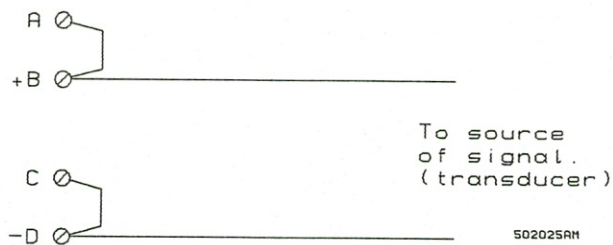

Fig. 2.3.3.a.

The modules input impedance is so high, that ordinary voltage division with two resistors can be used, if the signal to be measured is higher than 0-500 mV.

Example: Input signal 0-5 V. See fig. 2.3.3.b.

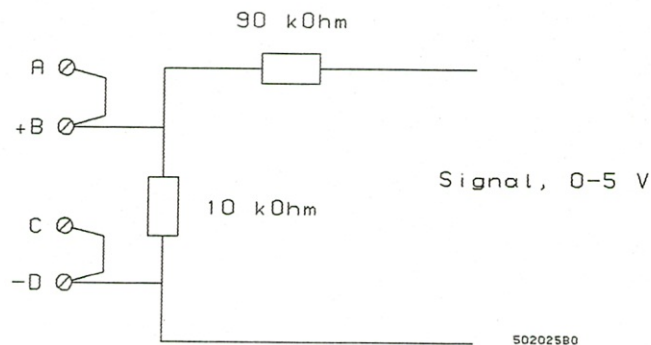

Fig. 2.3.3.b.

3. Conductivity Inputs.

The PD 1652 module has two inputs (channel 3 and 4) for measuring conductivity in two measurement ranges, either 1-10000 μ S or 0.1-1000 mS, according to how the electrodes are connected.

Using a particular register, the maximum range of the measurement can be defined. this facility is used in processes where the electrodes are frequently short-circuited.

To smooth out possible variation in the measured value, a fourth order filter can be inserted, in which the user can choose between two time constants (1.5 seconds, and 3 seconds).

As liquid conductivity is dependent on temperature, it is also possible to compensate for this temperature dependency.

Apart from the modules ability to perform two conductivity measurements on two independent channels, it is also possible to configure the module in SUM mode. In SUM mode the sum of the two measurements on the two conductivity channels is calculated. Furthermore, the difference between the two measurements can be calculated.

The measurement of conductivity is performed using a sine-shaped voltage of 1200 Hz, to avoid polarization of the electrodes.

3.1. Block Diagram of Conductivity Channels.

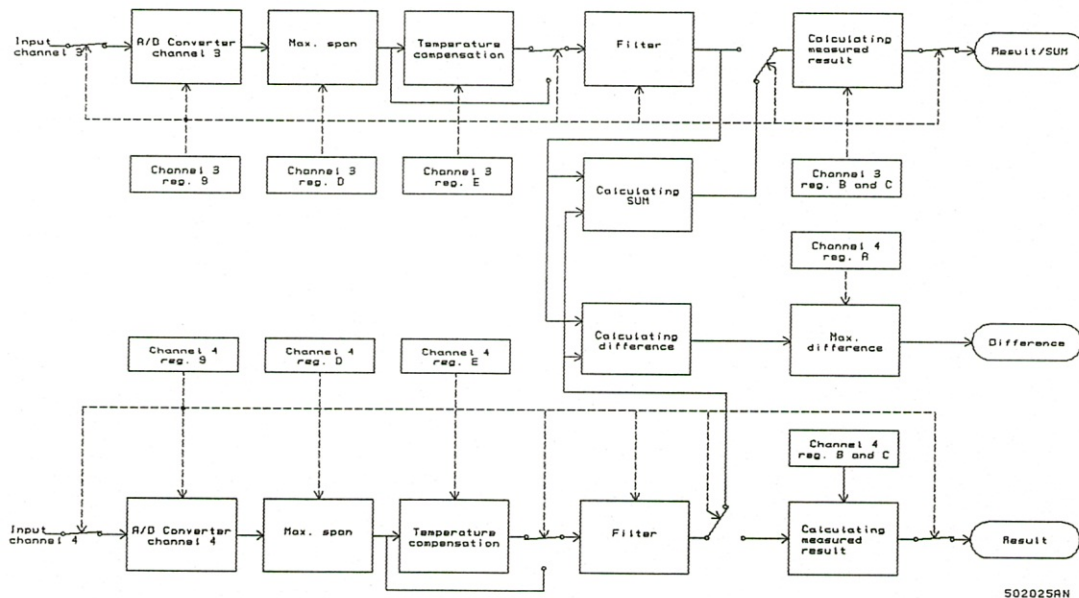

3.2. Registers on conductivity channel (channel 3-4).

Reg.no.	Register name	Write	Storage medium	Number of bytes	Read out
0	CondIn		R	4	Decimal
1	CondDiff ***		R	4	Decimal
2					
3	TCTemp *	X	BR	4	Decimal
4					
5					
6					
7					
8					
9	Code9	X	E	4	Hexadec.
A	MaxDiff **	X	E	4	Decimal
B	FullScale	X	E	4	Decimal
C	ZeroPoint	X	E	4	Decimal
D	MaxDelta	X	E	4	Decimal
E	TempCoeff	X	E	4	Decimal
F	Cherror		R	1	Hexadec.

* Indirect register

** This register only exists on channel 4

*** This register only exists on channel 3

Reg. 0: CondIn

The result of the conductivity measurement is found in this register.

Reg. B: FullScale

The value of register 0 at full signal on the conductivity input (100 μ S or 10 mS), is placed in the FullScale register.

Reg. C: ZeroPoint

The value of register 0 at minimum signal on the conductivity input (0 S), is placed in the ZeroPoint register.

Reg. D: MaxDelta

The user can define (in this register) the maximum transition in measures value allowed (eg at short circuit). The value is defined in % (0.3 = 30 %).

In SUM mode MaxDelta is used on channel 3.

Reg. F: CHError.

The error register shows whether there is an error on the channel currently, or whether there is a general error on the module which might lead to the channel concerned being defective.

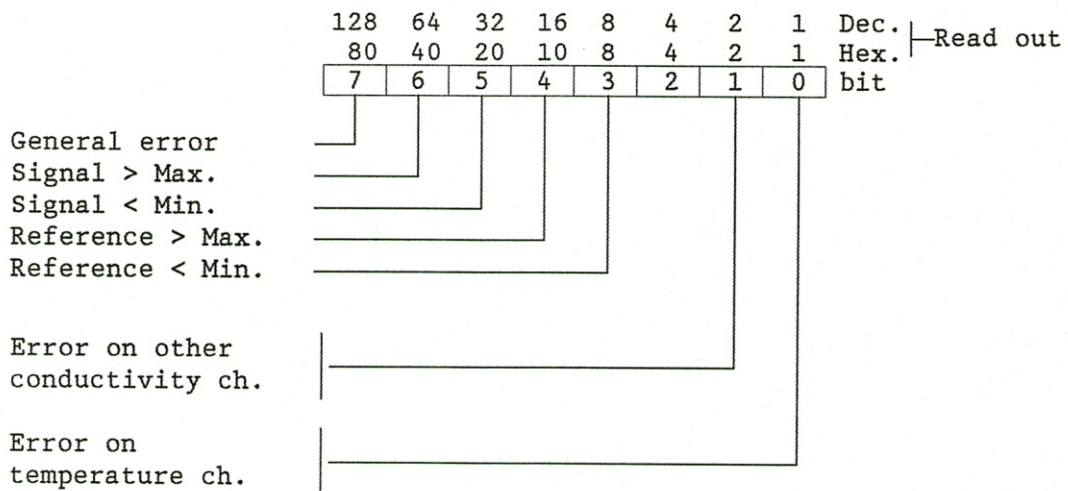

If bit 7 (general error) is set, then the other bits are insignificant, as the general error can be derived from error code on other channels (see Service channel).

Bit 6 (signal max.) is set when input signal attains a level higher than $10000 \mu\text{S} / 1000 \text{ mS}$. This indicates that the signal has exceeded the measurement range (eg, when the input is short circuited).

Bit 5 (signal min.) is set if the input signal becomes negative. This error can occur if the electrodes are not connected correctly.

Bit 4 (reference max.) is set if the internal reference level is too high. This error can be caused by a fault in the module.

Bit 3 (reference min.) is set if the internal reference level is too low. This can occur if the module has been connected wrongly, or if there is an error in the module.

If the channel is set in SUM mode, and an error occurs on one of the channels, then bit 1 in the error code on the other channel will be set.

If temperature compensation is connected, and an error occurs on the temperature channel, then bit 0 will be set.

3.3. Temperature compensated measurement.

Conductivity is dependent on the temperature of the liquid. In order to compare two conductivities at different temperatures, it is possible to compensate for temperature for the conductivity measured.

The display shows the equivalent of liquid conductivity at 20 °C.

$$End\ result = \frac{Res}{1 + TempCoeff (TCTemp - 20)}$$

The temperature which is used for compensating, could be taken, for example, from channel 1. That is address 10. So in order to compensate for temperature, address 10 is inserted in the first two digits of the code register for the conductivity channel.

Example:

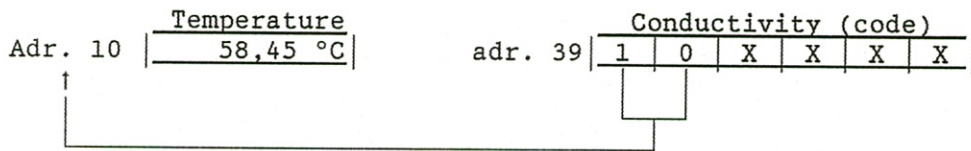

Reg. 3: TCTemp *

TCTemp is an indirect register from which the temperature used for temperature compensation can be read.

If the code register points to address 00, the register can be written to.

Reg. E: TempCoeff

When temperature compensation is selected, this factor can be used in deciding by how many percent the measured value should be compensated, per Deg C. The factor is given in % (0.01 = 1% per °C).

3.4. Measuring the SUM and difference.

The transmitter is designed to be able to calculate the SUM and difference of the two conductivity measurements. SUM is calculated with the following formula:

$$\text{Conductivity} = \frac{1}{\frac{1}{RES_1} + \frac{1}{RES_2}}$$

The difference is merely the two results subtracted from each other.

Reg. 0: CondIn

When the transmitter is programmed to calculate the sum of the two conductivity measurements, the sum result will be available on channel 3 **only** (Reg. 0).

Reg. 1: CondDiff

This register is only used when the transmitter is programmed for the SUM mode. The register is used to hold the difference between the two conductivity measurements. The register can only be read on channel 3.

Reg. A: MaxDiff

The maximum difference allowed between two channels is defined in this register (only if the module is in SUM mode). If this limit is exceeded, the module will generate an error. The limit is shown in percent of the sum (ie, 0.8 = 8%). This register exists only on channel 4.

3.5. Conductivity measurement with one electrode.

In order to measure conductivity, one or more electrodes need to be connected to one of the two sets of terminals associated with the conductivity channel. The terminals are marked "A-B-C-D".

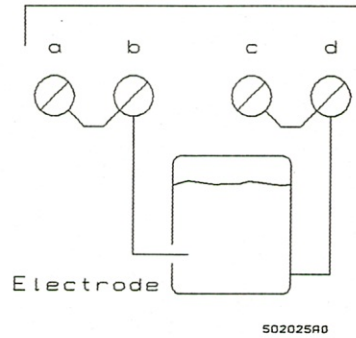

The shorting link between terminals can be removed depending on which measured range one wishes to use.

With short circuit: 0.1 - 1000 mS

Without short circuit: 1 - 10000 μ S

3.6. Conductivity measurement with two electrodes.

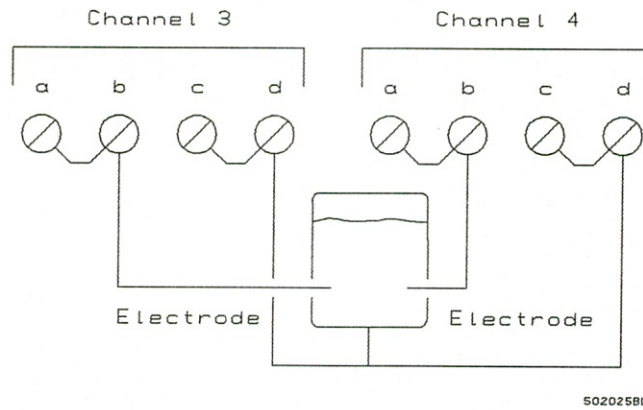

4. **Current Output.**

The PD 1652 module has a current output (4-20mA) which is an output channel (channel 2). The current output can be the result of a measurement, or a value set by the display unit PD 230, or the P-net.

The current output can also represent the output signal from an internal PID Regulator and can be used for control purposes.

The signal on the current output can be read via display-unit or P-net as a number between 0-100%.

Block diagram of current output function:

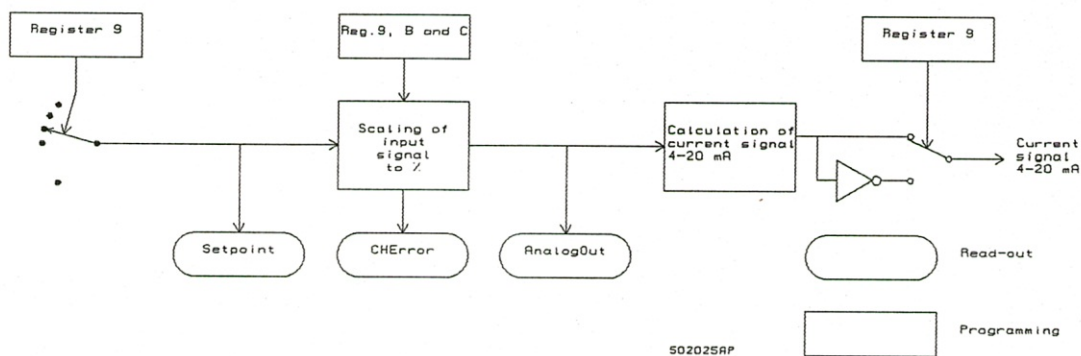

Registers in the current output channel (channel 5).

Reg.no.	Register name	Write	Storage medium	Number of bytes	Read out
0	AnalogOut		R	4	Decimal
1					
2					
3					
4					
5					
6					
7	Setpoint *	X	BR	4	Decimal
8					
9	Code9	X	E	4	Hexadec.
A					
B	FullScale	X	E	4	Decimal
C	ZeroPoint	X	E	4	Decimal
D					
E					
F	CHError		R	1	Hexadec.

* Indirect register.

Reg. 0: Analogue Out

Using this register the output signal can be displayed as a number between 0-100%.

Reg. 7: Setpoint *

The value which the current output is required to attain (if settled) can be seen in this register.

If the code register points to address 00, then this register can be written to.

Reg. 9: Code

Code register for the current output channel (Reg. 9)

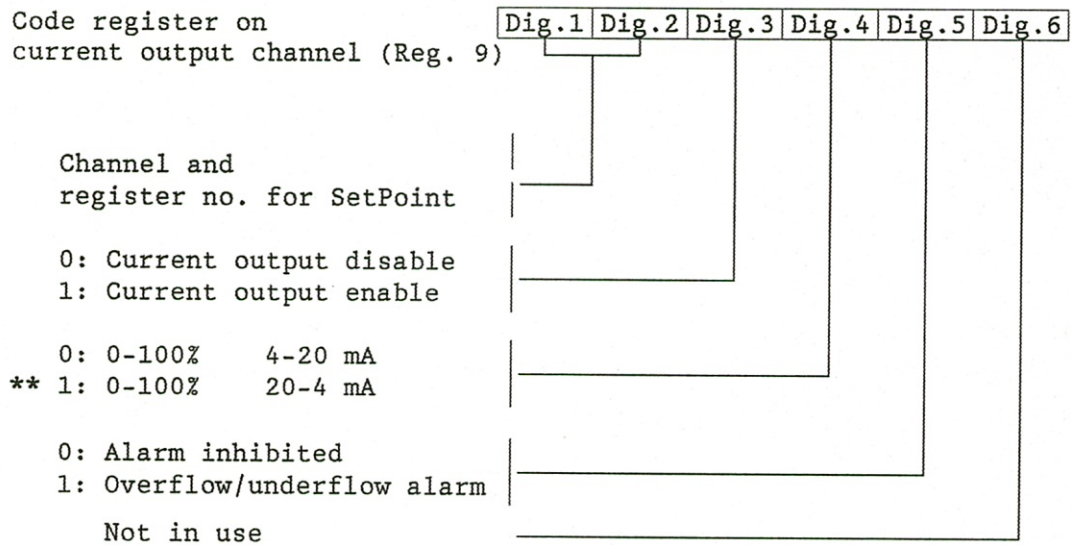

** Inverting the current output.

If an address in digit 0 and 1 is defined, then the corresponding indirect register can be written to.

An indirect register must not be pointed to by the two first digits in the code.

The current output can be disabled using digit 3 (current output disabled).

Using digit 4, it can be decided whether 100% will correspond to 20 mA or 4 mA.

The two alarms "overflow" and "underflow" (see register F) can be disabled by digit 5.

Reg. B: Fullscale

Fullscale is the value for which the max.output signal (100%) is required on the current output.

Reg. C: Zero Point

Zeropoint is the value for which the min.output signal (0%) is required on the current output.

Reg. F: CHError

The CHError register shows whether there is currently an error on the channel, or whether there is a general error in the module which might lead to the channel concerned being defective.

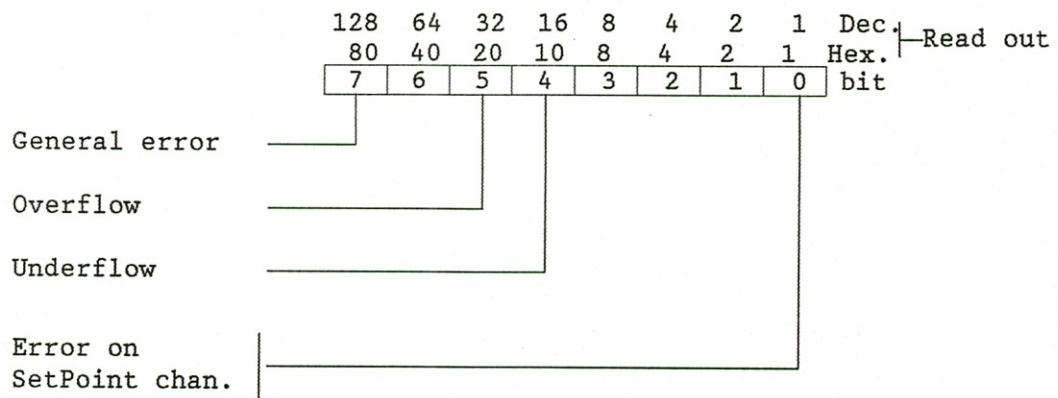

If bit 7 (general error) is set, then the other bits are insignificant, as the general error can cause additional errors on the channels (see for example "service channel" part 8).

Bit 5 (overflow) is set if the output is more than the fullscale value (Reg. B).

Bit 4 (underflow) is set, if the output is lower than the zeropoint value (Reg. C).

If Bit 0 is set, the module has found an error in the channel from where the output is derived.

4.1. Current Output, Electrical.

The current output is designed as a passive current generator and the voltage must therefore be applied from an external circuit (or perhaps from the built in voltage output in the module).

Fig. 4.1.a. Current output, schematic:

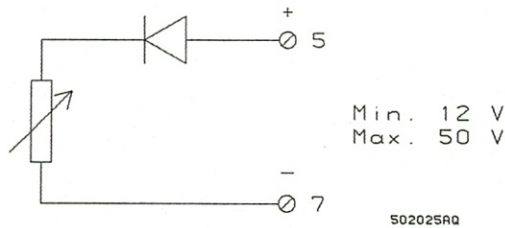

The current output is galvanically separated from the other part of the electronics by an opto-coupler. Furthermore, the output is protected against wrong polarization by a zenerdiode and a current limiting resistor as shown in the figure below. This resistance is rated so that limitation occurs at a current of approximately 35 mA. Before the output can be used again, the output must be disconnected totally for a few seconds.

The external control equipment must be rated such that the voltage over the current output range (terminal point 5 and 7 on the base circuit board) is always is min.12.v., the internal control circuitry, being supplied by this voltage.

Fig. 4.1.b. Current Output:

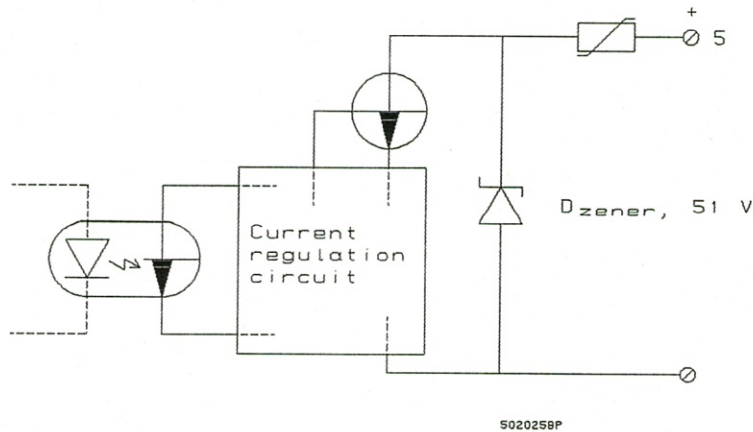

Fig. 4.1.c. Connection of current output with supply from the internal voltage output of the module:

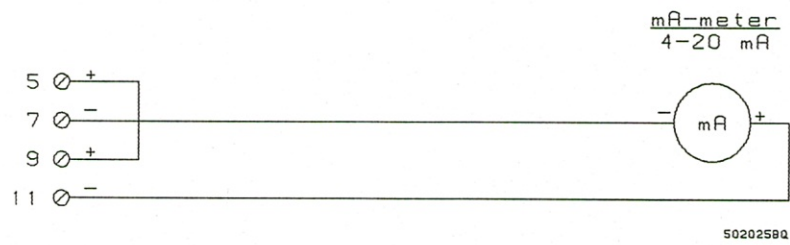
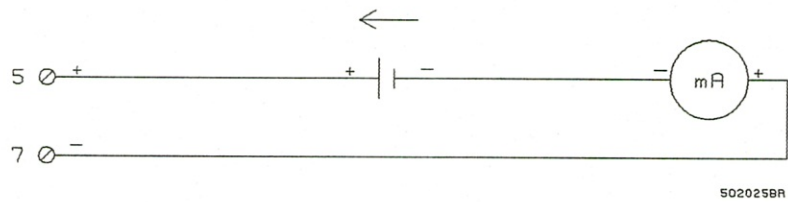

Fig. 4.1.d. Connection of current output with external supply:



5. PID Regulator.

The PD 1652 module is equipped with an internal PID regulator (channel 3), which can be used for various control purposes.

The PID regulator can be used both to control a current signal (4- 20,mA) or a cyclic signal (ie.a digital signal with a set frequency but variable on-time). This is done through other channels in the module.

The regulator is set with the P, I and D parameters and a code, which defines the input signals to the regulator.

It is possible to define three different signals to the regulator, 1,2 and setpoint.

The input signals can either come from the input channels of the module, or be input via display unit or P-net.

The signals 1 and 2 can be added, subtracted, multiplied, or divided with each other. Thus it is possible to set the module, for example, for proportional regulation between 2 measured values.

Using the display unit or the P-net, the regulator can be set to "Manual".

Block diagram of PID Regulator:

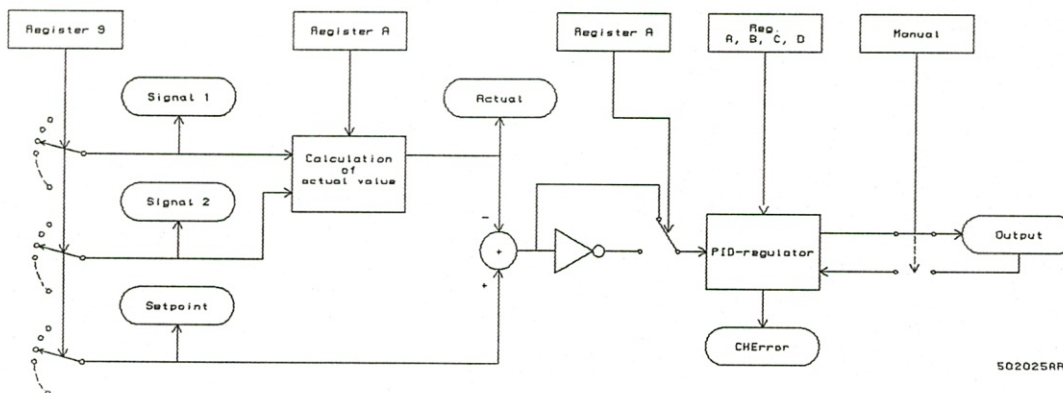

Registers for PID Regulator (channel 6)

Reg.no.	Register name	Write	Storage medium	Number of bytes	Read out
0	Output		R	4	Decimal
1	Signal1 *	X	BR	4	Decimal
2	Signal2 *	X	BR	4	Decimal
3	Actual		R	4	Decimal
4					
5					
6					
7	Setpoint *	X	BR	4	Decimal
8	FagReg8	X	R	1	Binary
9	Code9	X	E	4	Hexadec.
A	CodeA	X	E	4	Hexadec.
B	Xp	X	E	4	Decimal
C	Ti	X	E	4	Decimal
D	Td	X	E	4	Decimal
E					
F	CHError		R	1	Hexadec.

* Indirect Registers.

Reg. 1: Signal1 *

The selected input value for signal 1 can be seen in this register.

Reg. 2: Signal2 *

The selected input value for signal 2 can be seen in this register.

Reg. 3: Actual

The result of the calculation using the two input values (signal 1 and signal 2) is stored in this register. See Section 4.1.

Reg. 7: Setpoint *

The setpoint, which is used for PID regulator control, can be read from this register.

Reg. 0: Output

The output signal from the PID-regulator can be read from this register as a number between 0 and 100%. If the output should exceed 100%, then the output register will statizize at 100%. Also the module will generate an error code (see register F). This also occurs if the output signal drops below 0%.

Reg. 8: FlagReg8

This flag register can be used for switching between automatic & manual control. That is done by writing a 0 or 1 into the register, as shown below:

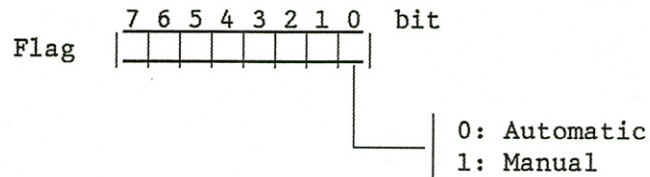

When the regulator is in "Manual" it is possible to preset an output value, using the display unit or P-net. When the regulator is reset to automatic, the control will continue from the set output signal. This facility is called "Bump-less transfer" and can be used, for example, for avoiding overshoots at startup when using a very slow control-loop.

The "Manual" facility can also be used for a quick zero-setting of the output signal, for example in an alarm situation.

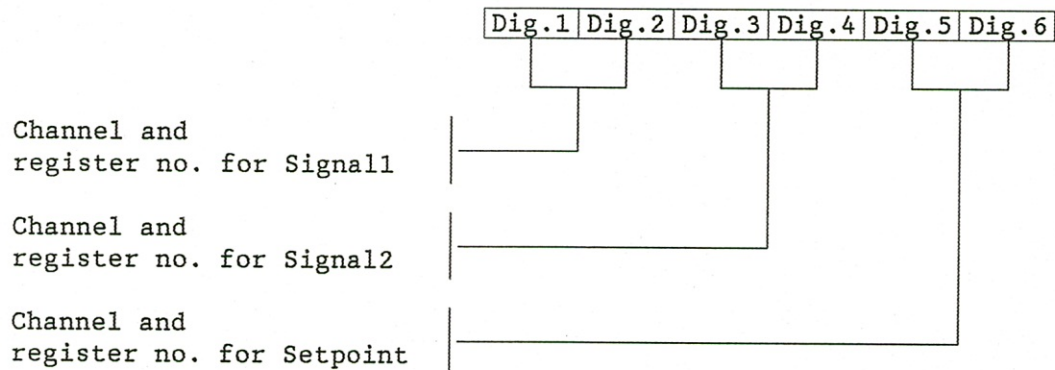
Register 9: Code 9

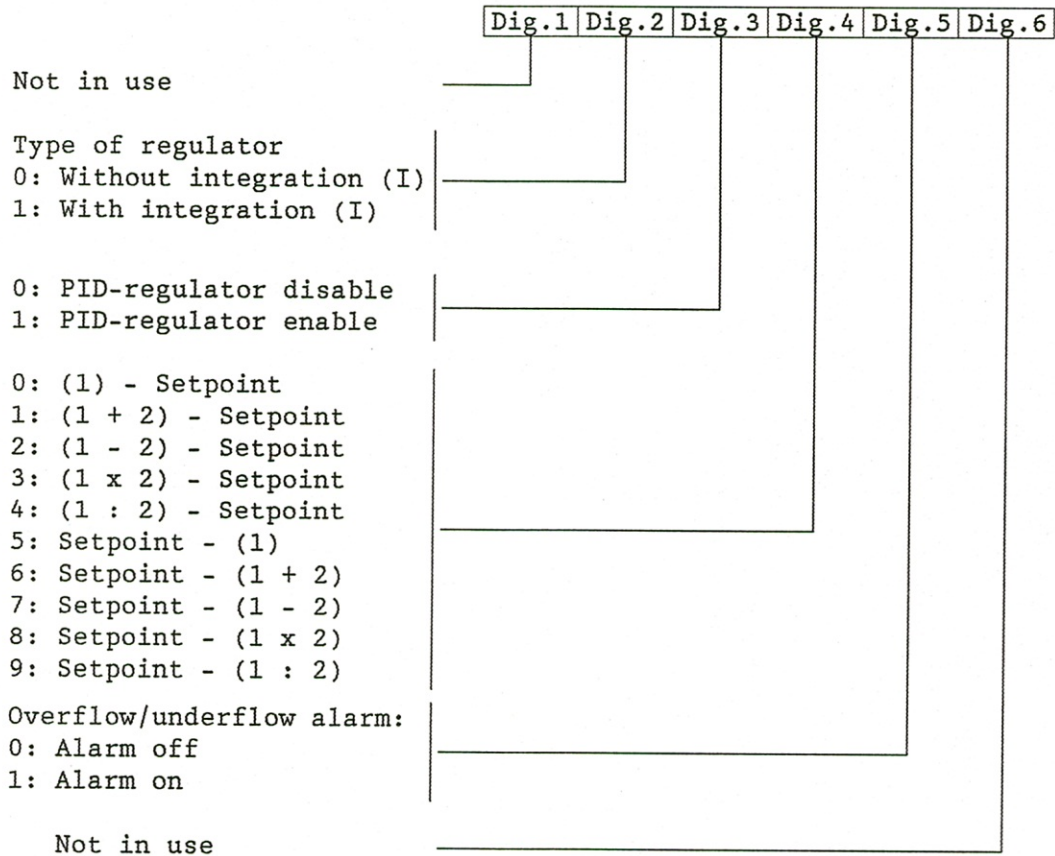
Register A: Code A

Using digit 2 of the code register (Reg.A) the regulator's integration time (I) can be disabled.

Digit 3 is used for enabling/disabling the PID regulator. If the regulator is not required, then digit 3 must be set to a 0, to avoid possible errors in the channel.

Digit 4 is used to select how the regulator should calculate the output value (as described above).

Digit 5 is used to select whether the overflow/underflow alarm is enabled/disabled (see Reg. F).

Reg. B: Xp

Xp is the PID regulator's proportional band. The proportional band for a regulator is the change required in the input signal to give a change from 0 to 100% in the output signal (without I and D). Xp is defined in the same units, as the input signal to the regulator.

Reg. C: Ti

Ti is the integration time constant for the regulator, which is the time it takes for the I-component of the regulator to give the same change in the output signal as that made by the P- component, following a permanent change of the input signal.

The I-effect in the regulator is minimised by setting Ti to a very high value. Ti is defined in seconds.

Reg. D: Td

Td is the regulator's differentiation time. The differentiation time for a regulator, is the time a constantly rising input signal must take to rise from 0-100% (equivalent to X_p) in order to give a constant output signal of - 100% (without P and I).

As the signal from the D-component in the regulator is negative when the input signal is rising, the component will act as a "brake" on the output signal.

The D-component in the regulator can be totally disabled by setting Td to 0. Td is defined in seconds.

If problems arise in setting the three parameters P, I and D, please refer to technical literature on the subject.

Reg. F: CHError

The CHError register indicates whether there are any current errors on the channel, or if there is a general error on the module, which could result in the channel being faulty.

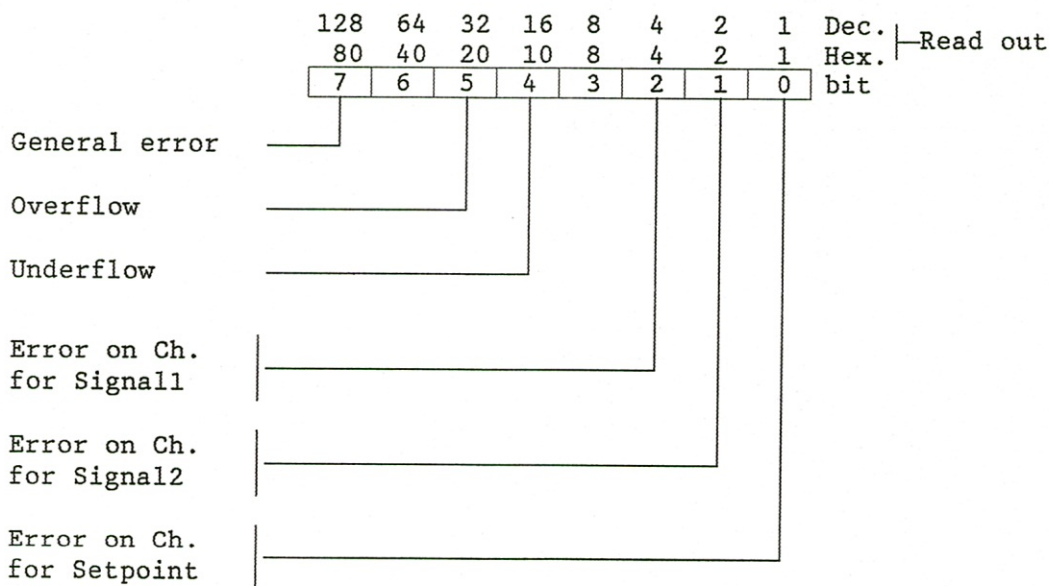

If bit 7 (general error) is set then the other bits are insignificant, as the general error can lead to other errors on the channels (see Service Channel in section 8).

Bit 5 (overflow) is set when a result is above 100%.

Bit 4 (underflow) is set if a result falls below 0%.

Bit 0-2 indicates whether there is an error on the channel from where Setpoint, signal 2 and signal 1 respectively, have been taken.

5.1. Calculation of Actual Value.

As previously mentioned, Signal 1 and Signal 2 can be added, subtracted, multiplied or divided with each other. It is therefore possible to choose various forms of control. The result of the chosen calculation will be stored in the Actual register (reg.3).

As an alternative, one can store signal 1 directly in the Actual register.

To select the input signals to the PID regulator (signal 1 and signal 2), the code register must be programmed as shown in the example below.

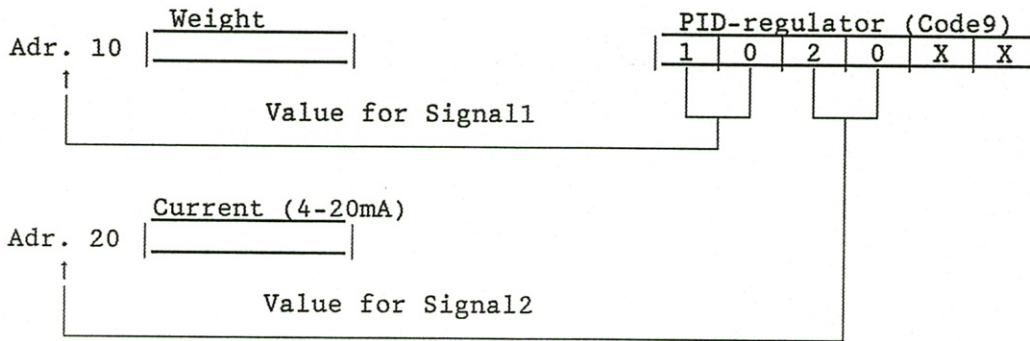
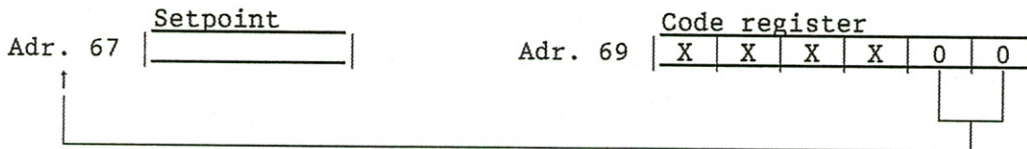

Fig. 5.1.a.

The regulator utilises values from the Actual register and a selected value in the Setpoint register.

The address from which the Setpoint collects data, is selected through the code register (reg.9) as shown in the example below.



Note: When pointing at adr. 00 by means of a code register, it is possible to write directly in the belonging indirect register. I.e. when writing "0" in channel no. and register no. for Setpoint (digit 5 and 6 in reg. 9), it is possible to write directly in the Setpoint register (reg. 7).

When a difference occurs between the Actual value and Setpoint, it can be corrected by making the output value rise or fall. This choice is made using an inverter, selected by a code register change.

Using digit 4 in the code register (reg.A), signal 1 and signal 2 can be added, subtracted, multiplied or divided, and defines whether inversion should be used.

		Code register						
Adr. 6A		1	2	3	4	5	6	digit
0:	(Signal1) - Setpoint							
1:	(Signal1 + Signal2) - Setpoint							
2:	(Signal1 - Signal2) - Setpoint							
3:	(Signal1 x Signal2) - Setpoint							
4:	(Signal1 : Signal2) - Setpoint							
5:	Setpoint - (Signal1)							
6:	Setpoint - (Signal1 + Signal2)							
7:	Setpoint - (Signal1 - Signal2)							
8:	Setpoint - (Signal1 x Signal2)							
9:	Setpoint - (Signal1 : Signal2)							

The result of the expression in the brackets will be stored in the Actual register.

If the Actual value is greater than the Setpoint value, the following is true:-

- ** These 5 functions will result in a falling output value (eg.Reheating), i.e. the inverter is connected.
- *** These 5 functions will result in a rising output value (e.g. cooling), i.e. the inverter is disconnected.

5.2. Example of simple regulation.

This type of regulation can, for example, be used in processes where one wishes to regulate the temperature in a container.

In addition to the PID-regulator, one uses the current output and one of the two analog inputs, programmed to measure temperature.

The current output controls a valve which, by means of a steam pipe, regulates the temperature in the container.

The analog input measures the temperature in the container by means of a temperature detector (Pt-100).

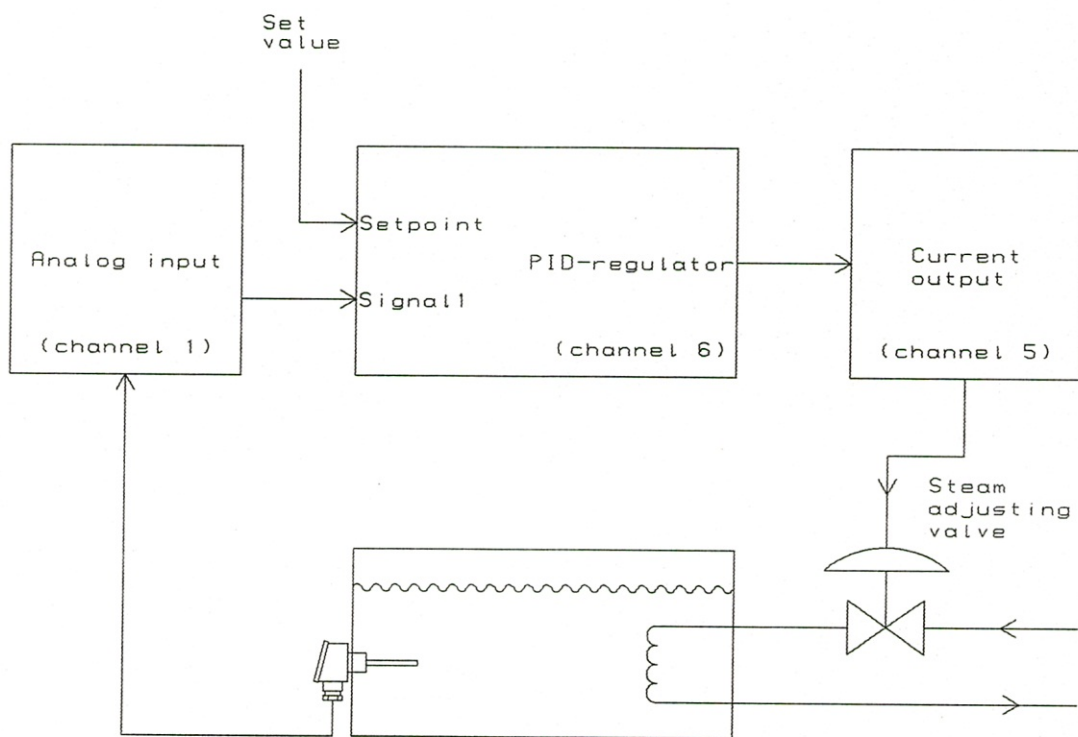

50202585

Setting a code register.

The analog input is programmed to measure temperature. The result of the measured temperature is placed in address 10, from where the PID-regulator can fetch its input signal. Apart from the temperature input signal the regulator needs a setpoint-value, which is inserted in the SetPoint register. These two input signals to the regulator are selected in the code register (Reg. 9), which is programmed as follows:

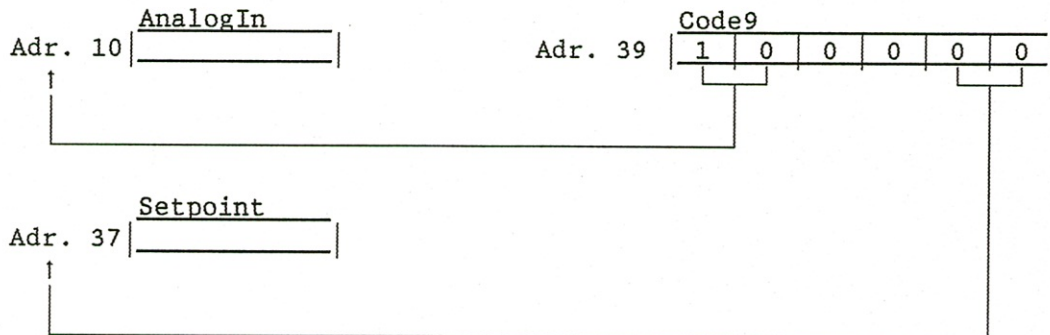

The other code in the PID-regulator channel can, for example, be programmed as follows:

CodeA					
0	1	1	5	1	0

Then the three parameters P, I and D (Tp, Ti and Td) must be inserted.

The output value for the PID-regulator is placed in the output register (Reg. 0), ie, the current output must be programmed to follow this value.

5.3. Example of sequence regulation.

This type of regulation can, for example, be used in processes, where one wishes to make a temperature in a container follow the temperature in another container, perhaps with a set difference.

Apart from the PID-regulator, one uses the current output and the two analog inputs, programmed to measure temperature.

The current output controls a steam valve which regulates the temperature in the container. The two analog inputs measure the temperature in each container by means of temperature detectors (Pt-100).

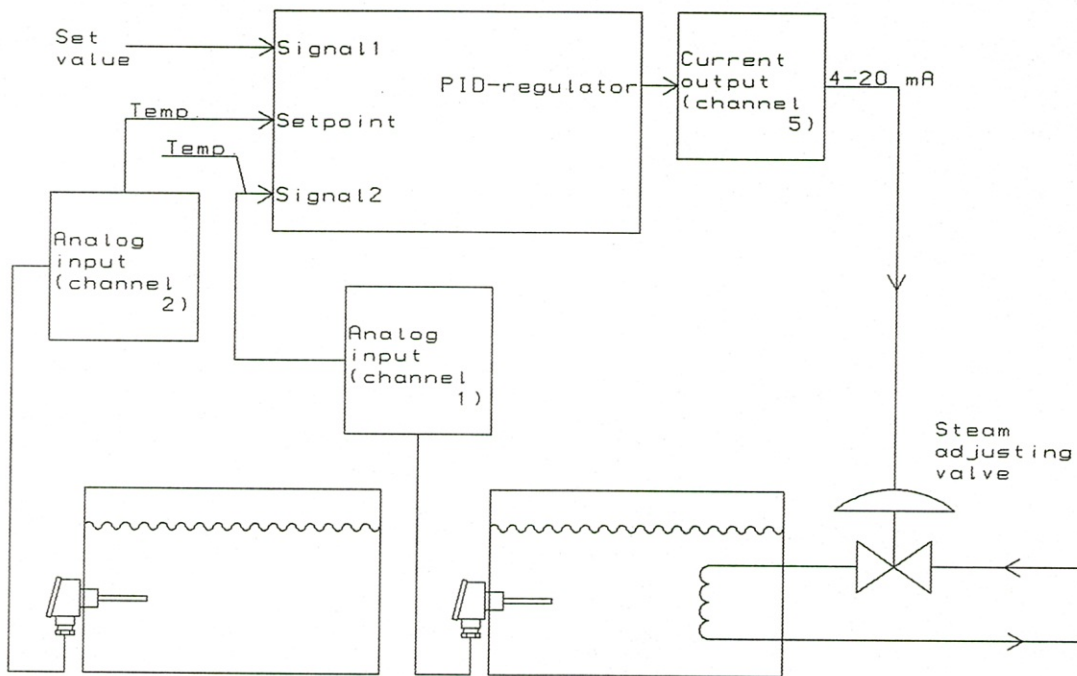

502025RT

Setting code registers.

The analog inputs are programmed to measure temperature. The results of the temperatures measured will be placed in address 10 and 20, from where the PID-regulator fetch its input signals. Apart from the two temperature input signals, the regulator needs a difference setting which is inserted in the signal 1 register. These three input signals to the regulator are pointed to by the code register (Reg. 9), which is programmed as follows:

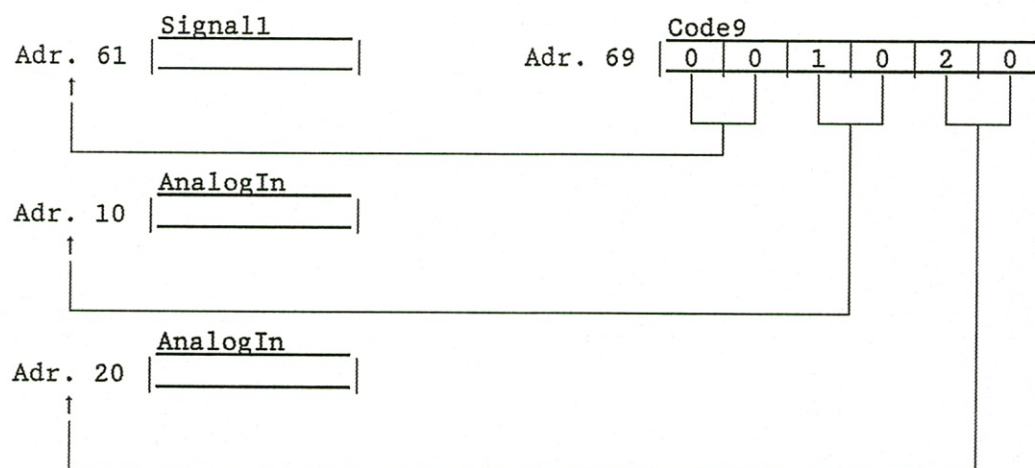

The other code in the PID-regulator channel can, for example, be programmed as follows:

CodeA
 Addr. 6A | 0 | 1 | 1 | 6 | 1 | 0 |

Then the three parameters P, I and D (T_p , T_i and T_d) must be inserted.

The output value for the PID-regulator is placed in the output register (Reg. 0), ie, the current output must be programmed to follow this value.

5.4. Example of pressure difference regulation.

This type of regulation can, for example, be used in processes, where, one wishes to control pressure by means of the difference between two pressures.

In addition to the PID-regulator, one uses the current output and the two analog inputs, programmed to measure current (4-20 mA).

The current output controls a valve which directly controls the pressure in the pipe.

The two analog inputs measure current (4-20 mA), which represents the pressure in two different pipes.

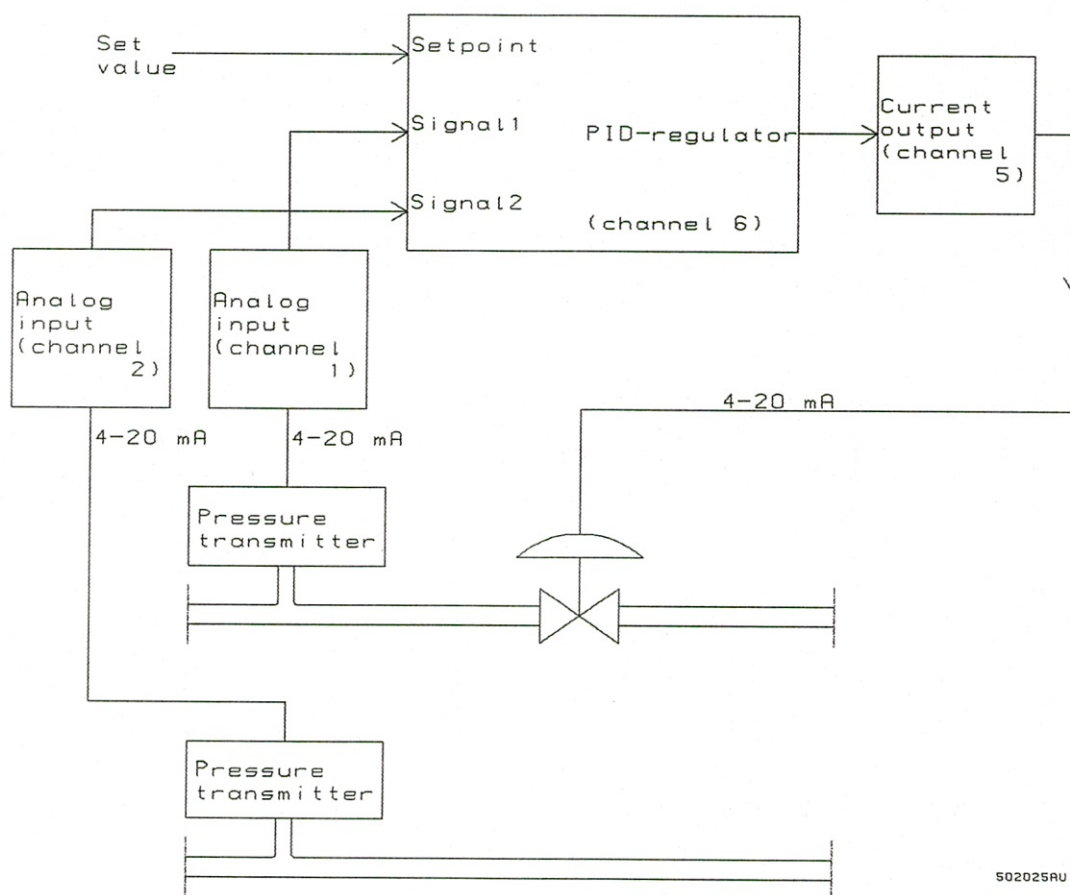

502025RU

Setting code registers.

The analog inputs are programmed to measure current (4-20 mA). The result of the measured currents will be placed in address 10 and 20, from where the PID-regulator can fetch its input signals. In addition to the two current signals, the regulator needs a setpoint value which is inserted in the SetPoint register. These three input signals to the regulator are pointed to by a code register (Reg. 9), programmed as follows:

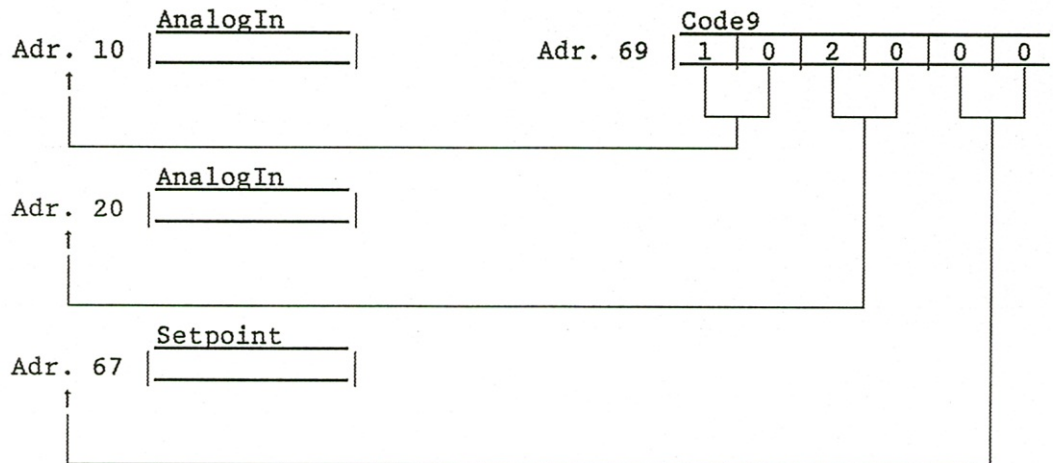

The other code on the PID-regulator channel can, for example, be programmed as follows:

Addr. 6A

CodeA					
0	1	1	7	1	0

Then the three parameters P, I and D (Tp, Ti and Td) must be inserted.

The output value for the PID-regulator will be placed in the output register (Reg. 0), ie, the current output must be programmed to follow this value.

5.5. Example of scaling by means of PID regulator.

If it is required to scale a measured value, it can be done with the PID regulator. For example, to multiply a frequency reading with a set scaling value.

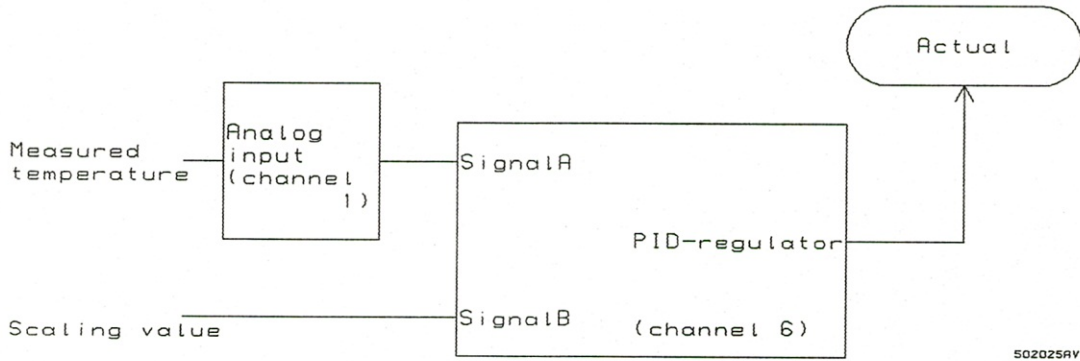
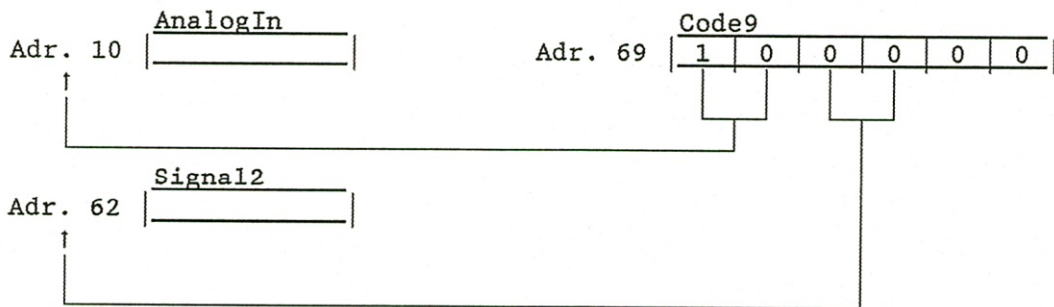

Fig. 5.5.a.

Setting Code Register

The analog input (channel 1) is programmed to measure temperature. The result of the measured temperature will be placed in address 10, from where the PID regulator can fetch one of its input signals. Apart from the temperature input signal, the regulator needs a scaling value, which is inserted in the Signal2 register. These two input signals to the regulator are pointed to by a code register (Reg. 9), which is programmed as follows:



The other code register on the PID-regulator can be programmed as follows:-

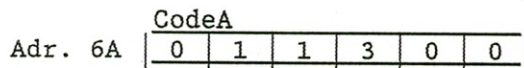

The final value after scaling can be read in the Actual register (reg. 3).

5.6. Example of proportional regulation.

This type of control can be used for example, in processes whereby one wishes to control a flow by means of the ratio between two flows.

In addition to the PID-regulator, the modules current output is used.

The measured results from the two flow transmitters are transferred by means of computer via the P-net (this data could also be transferred, for example, by means of a current signal).

The current output controls a valve which determines the flow through the pipe.

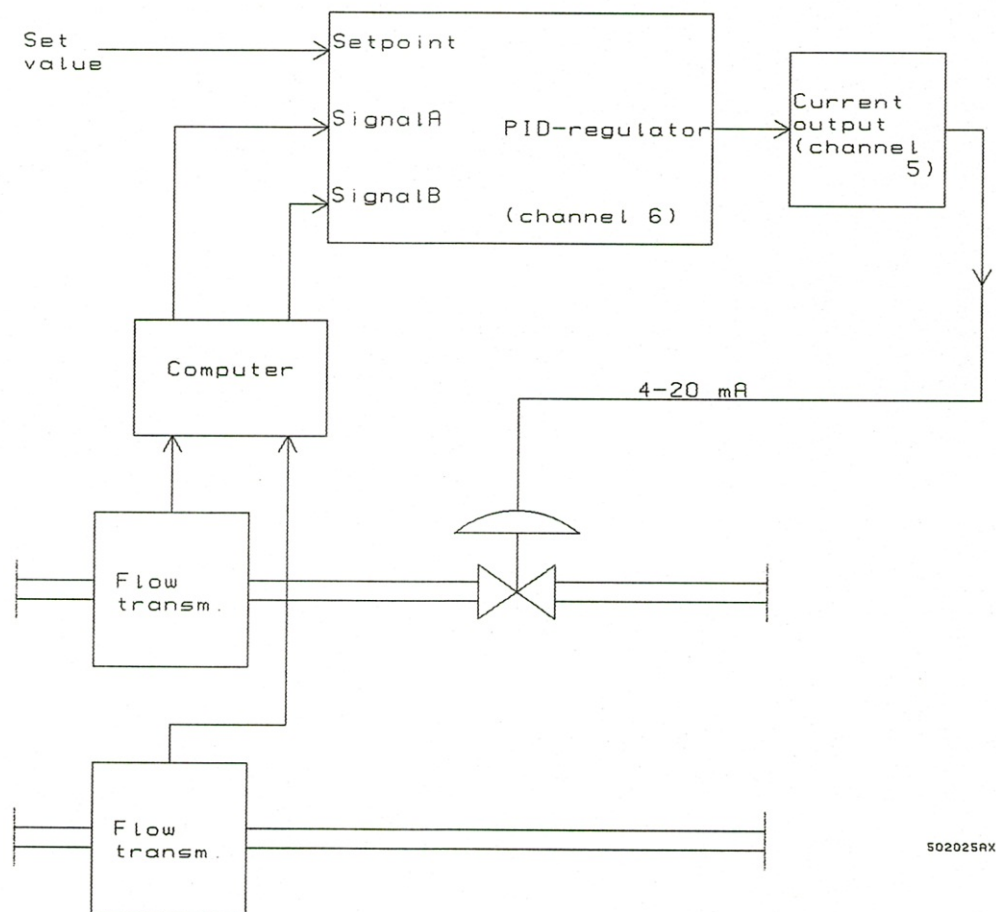

502025AX

Fig. 5.6.a.

Setting the Module.

The two measured results from the flow transmitters are placed by the computer, each in its own register. In addition, the regulator needs a fixed setpoint value, which is inserted in the SetPoint register. These three input signals to the regulator, are pointed to in a code register (Reg. 9), which is programmed to do the following:

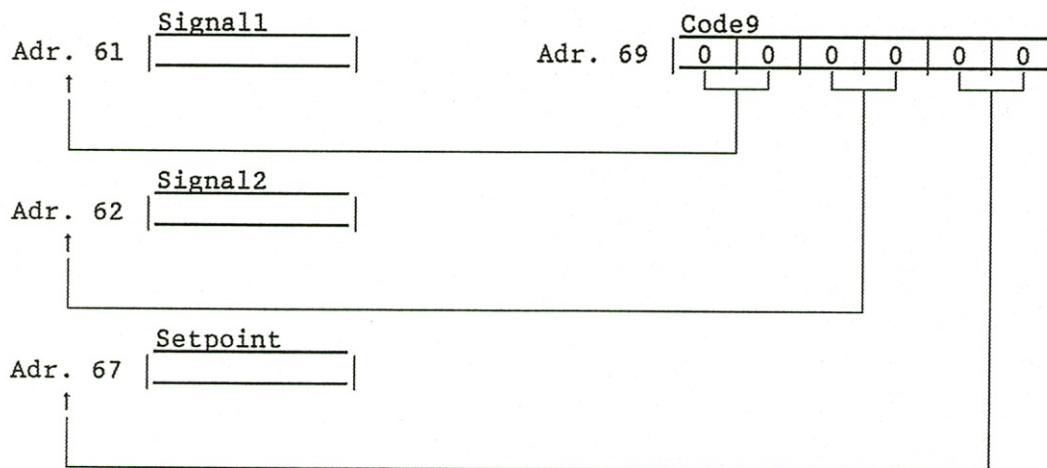

The other code on the PID-regulator channel can be programmed as follows:

Adr. 6A | CodeA |
 0 | 1 | 1 | 9 | 1 | 0 |

The three parameters, P, I and D (Tp, Ti and Td) can now be set.

The output value from the PID regulator is placed in the output register (reg.0), i.e. the current output must be programmed to follow this value.

6. Limit Switch / Batching Channel.

The module has two limit switch/batching channels (channel 7 and 8). The channels can, for example, be used as alarm detectors from two measurement values (Actual1 and Actual7), where both values can be defined by the user. Each of the two channels can control two flags, each with each own corresponding Offset value.

Diagram showing limit switch/batching channel:

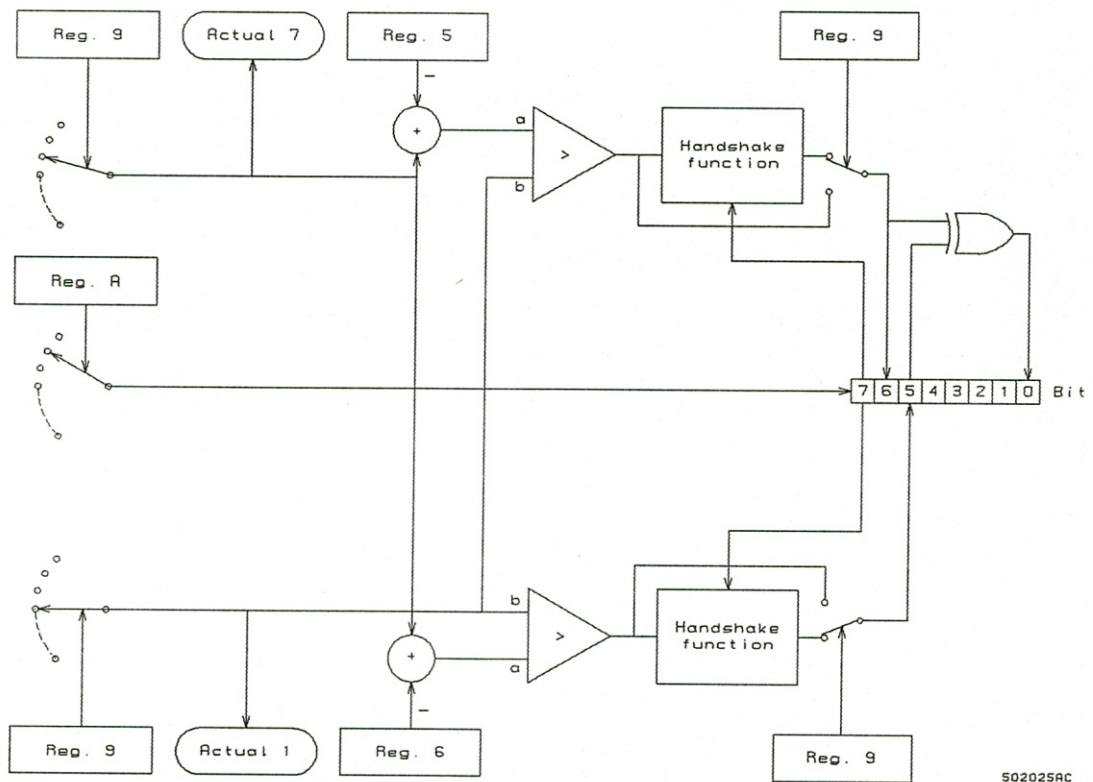

502025AC

Fig. 6.a.

Registers for Limit Switch / Dosage Channel (channel 7-8)

Reg.no.	Register name	Write	Storage medium	Number of bytes	Read out
0	FlagReg	X	R	1	Binary
1	Actual1 *	X	BR	4	Decimal
2					
3					
4					
5	ActOffset1	X	BR	4	Decimal
6	ActOffset2	X	BR	4	Decimal
7	Actual7 *	X	BR	4	Decimal
8					
9	Code9	X	E	4	Hexadec.
A	CodeA	X	E	4	Hexadec.
B					
C					
D					
E					
F	CHError		R	1	Hexadec.

*Indirect register

Reg. 0: FlagReg

The flag register contains Batch Flag 1 and Batch flag 2, which are controlled automatically. These two flags works as the output state for the channel, ie, a digital output can follow one of these flags. An Exclusive Or function on the two Batch-flags is automatically carried out, and is placed in bit 0. Furthermore a Handshake bit exists, which is used to start batching.

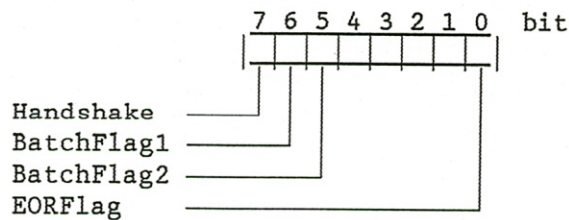

Reg. 1: Actual1.*

In this register, the Actual1 value, pointed to by means of the code, can be read.

If the code register points to address 00, then the register can be written to.

Reg. 5: ActOffset1.

The offset value for controlling Batch-Flag1 is inserted in this register.

Reg. 6: ActOffset2.

The offset value for controlling Batch-Flag2 is inserted in this register.

Reg. 7: Actual7. *

The Actual7 value chosen by means of the code (Reg. 9) can be read in this register.

If the code register points to address 00, one can write into the register.

Reg. 9: Code9.

Code register for limit switch/batch channels (Reg. 9).

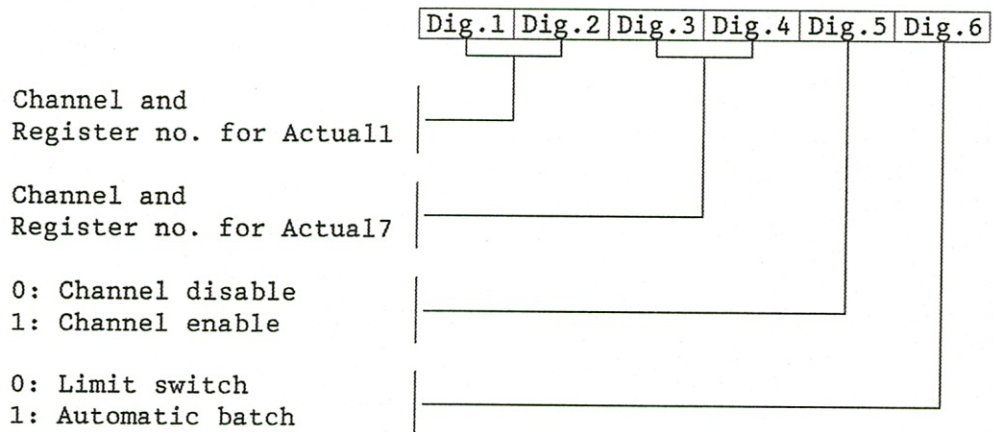

An indirect register must not be pointed to by means of the first four digits in the code as this could lead to errors being generated.

The channel can be inhibited by use of digit 5. If it is not required to use the channel, a 0 must be inserted in digit 5 in order to avoid errors being generated on the channel.

Digit 6 determines whether the channel will operate as a switch or for batching purposes.

If address 00 is pointed to by digits 1-4, then the corresponding indirect register can be directly written to.

Reg. A: CodeA.

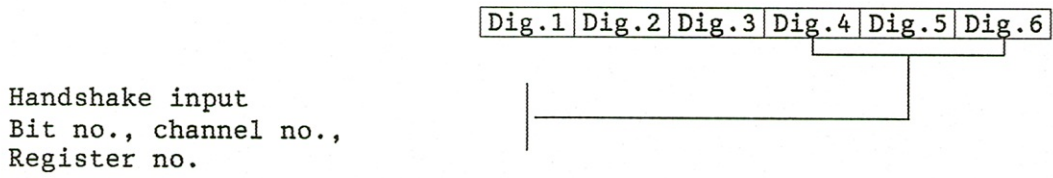

If it is required to control the Handshake flag by means of another bit, for example an input flag on a digital input, then this can be done by pointing to the selected bit, ie, bit No, channel No. and register No must be known. If this function is not desired, a 0 must be inserted in digit 4, 5 and 6, then the handshake flag can be controlled directly in FlagReg (Reg. 0).

Note: When the handshake flag is set to follow an input, the input must only be activated for a short time, otherwise the batching will never start (not less than 250 ms).

Reg. F: CHError.

The CHError register shows whether there is an error on the channel concerned, or whether there is an error on the module as a whole, which might lead to the channel being defective.

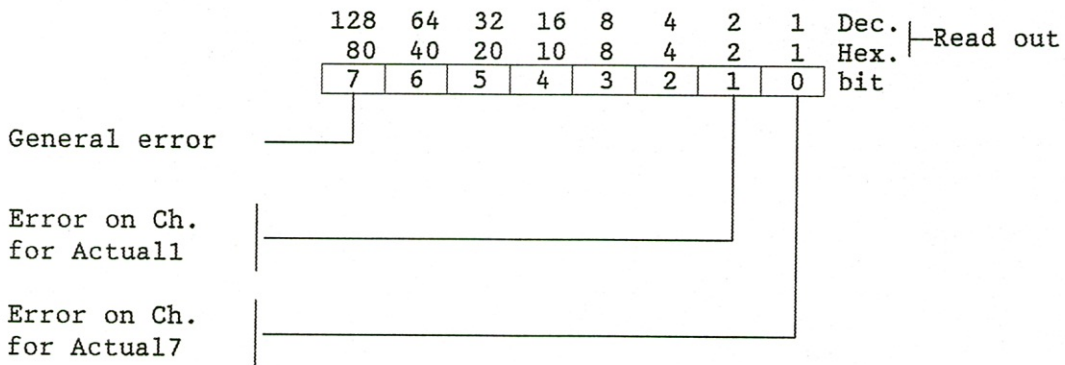

If bit 7 (general error) is set, then the other bits are insignificant, as the general error can be caused by error codes on the other channels (see Service channel).

Bit 1 is set if an error occurs on the channel from which the Actual1 value is fetched.

Bit 0 is set if an error occurs on the channel from which the Actual7 value is fetched.

6.1. Limit Switch, function.

The channel can be used as a limit switch to monitor a fluctuating signal (eg, a temperature measured on one of the two analog input channels).

6.1.1. Limit Switch, example.

Fig 6.1.1.a. shows an example of how this limit switch could be used.

By means of the code register (Reg. 9) the Actual7 value is given as the fluctuating input signal. Actual1 is defined as a fixed setpoint; this is done by pointing to address 00, and writing directly in the Actual1 register. Furthermore a tolerance around the setpoint value can be set by means of the two offset values, because ActOffset1 is made negative and ActOffset2 positive. Thus each of the two batch flags corresponds to an offset value.

BatchFlag1 will be OFF until Actual7 exceeds Actual1 + ActOffset1. Likewise, BatchFlag2 will be OFF until Actual7 exceeds Actual1 + ActOffset2. The two offset values are thus used to determine how a time must elapse from when the Actual7 value reaches the setpoint (Actual1) until the BatchFlag must change; so by making one offset value negative, one can determine how long a time must elapse from when the BatchFlag changes, until the Actual7 value reaches the setpoint (Actual1).

If one wishes to test whether the Actual1 value lies within or outside the limits, one can use the EORFlag. The EORFlag is set when the Actual1 value lies within the limits. If the opposite function is desired, this can be done by means of the digital output channel, as it is possible to connect an inverter before the digital output, ie, the digital output goes ON, when the EORFlag is OFF.

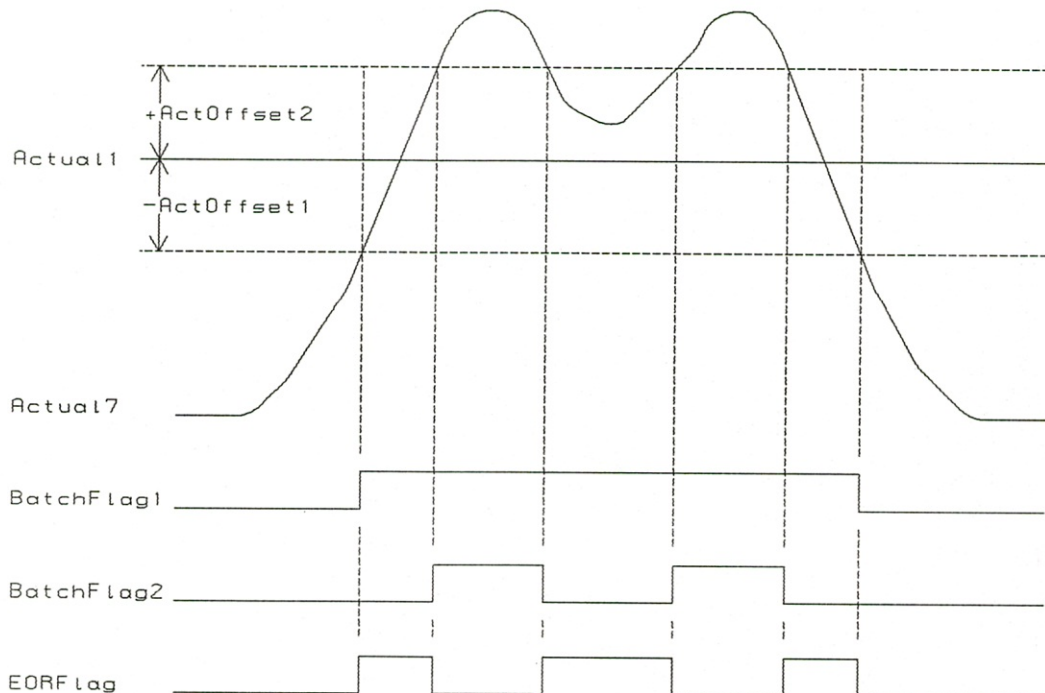

502024RZ

6.1.1.a.

6.1.2. Limit Switch with positive offset values, example.

One can also select to make both offset values positive, as shown in fig. 6.1.2.a.

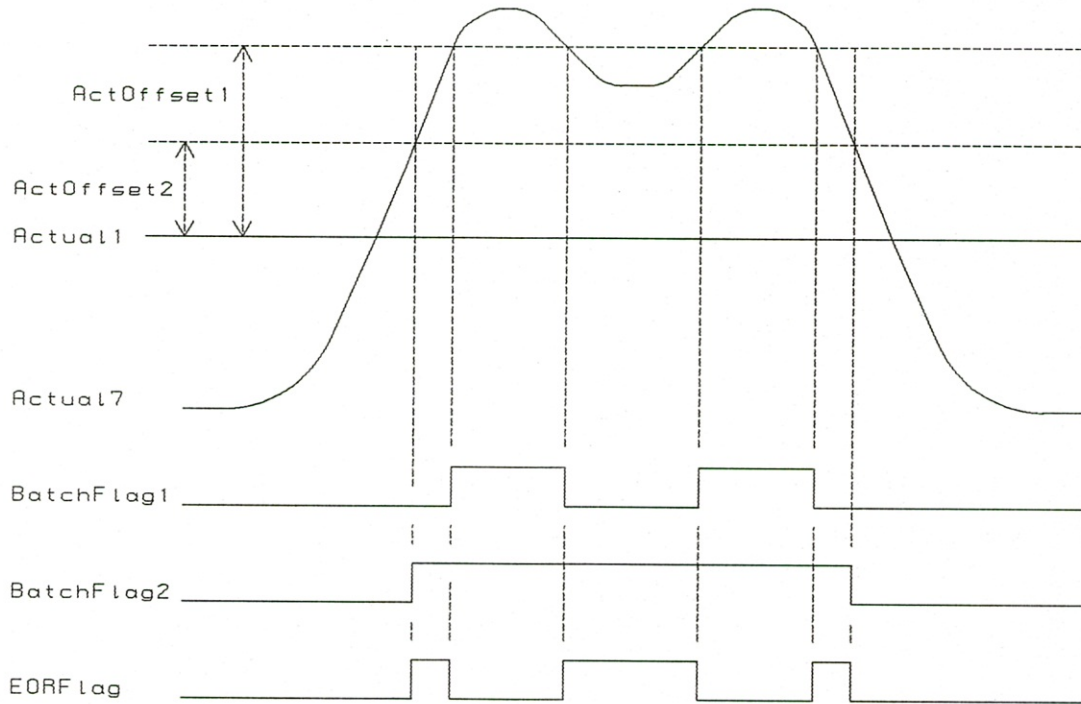

5020248A

6.1.2.a.

6.2. Batch run.

This channel can also be used for batching purposes. The batch runs until the measured value (Actual1) equals the desired number (Actual7). A batch channel can control two flags (in Reg. 0) from the same measured value and the same setpoint, but with two different setpoint Offset values (ActOffset1 and 2) - one for each flag. These offset values are used for example, when batching with two speeds or when dosing with a slow value. When the number still to come equals the offset value, the batch will be stopped.

The batch is set up by supplying the channel with its input signals (Actual1, Actual7, ActOffset1 and ActOffset2), then the batch can be started by setting the Handshake flag. This flag will be cleared automatically, and only then will the two batch flags be stable, ie, they can be read via the P-net.

When the two batchflags have been cleared, they cannot be set again unless the batch is restarted by setting the Handshake flag.

BatchFlag1 will be ON until Actual1 exceeds Actual7 - ActOffset1. Batchflag2 will be ON until Actual1 exceeds Actual7 - ActOffset2. The two offset values must therefore be positive numbers.

Below is shown an example of a batching system for dosing.

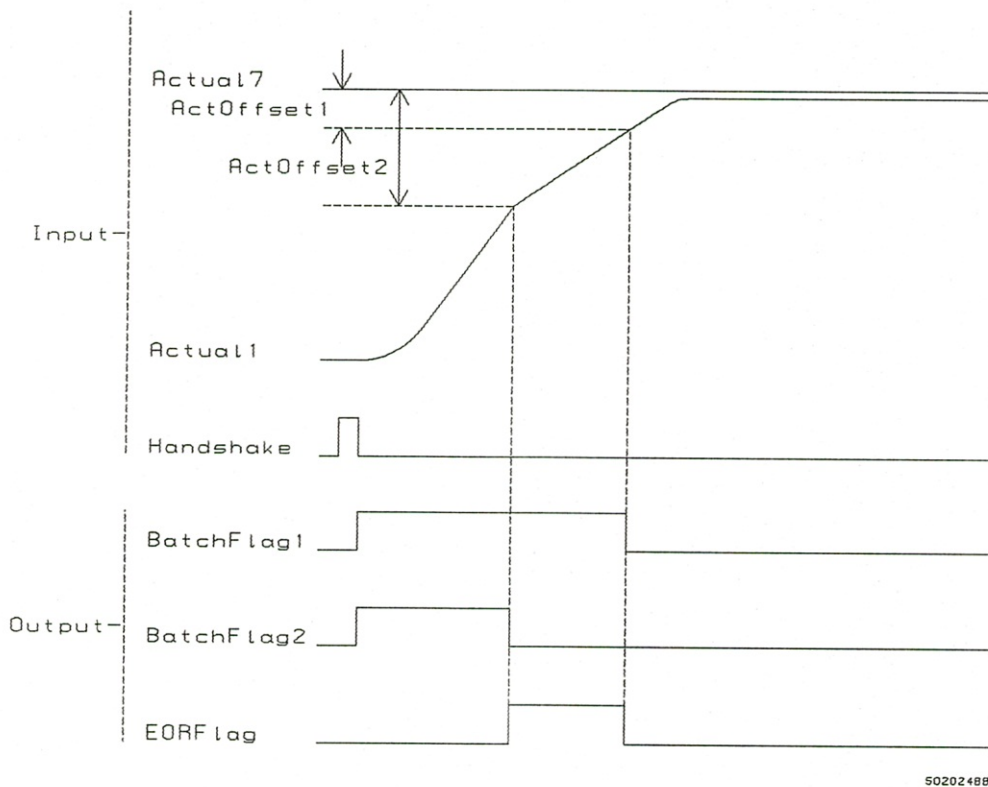
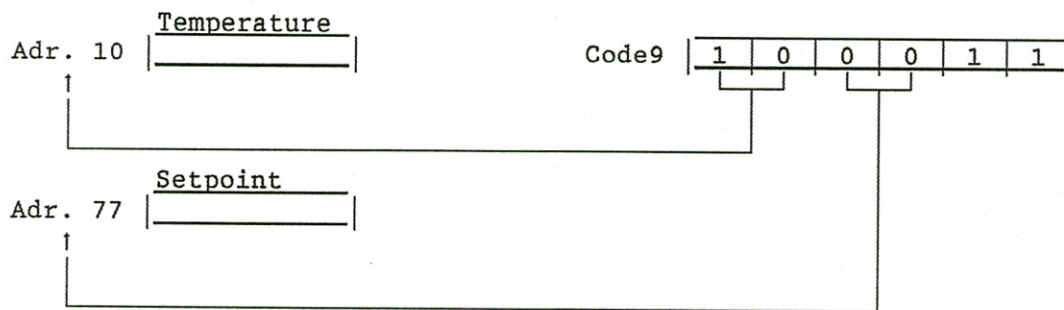

Fig. 6.2.a.

Setting the code register.

In order to define the Actual1 and Actual7 values, the desired values must be pointed to by means of a code register, as shown in the example below.

The Actual1 value can, for example, be a temperature, measured by means of an analog input (channel 1), and Actual7 can be a fixed defined value.



7. Input Channels, measuring of frequency.

The PD 1652 module is equipped with a digital input channel (channel 9) for measuring of frequency (max. 250 Hz).

The digital input circuit is configured as a passive input i.e. the input connection must have a voltage applied from an external circuit (or via the internal voltage output of the module). Also, the inputs are galvanically isolated from other parts of the electronics by an optocoupler. The inputs are also protected against overloading due to incorrect polarization.

Block diagram of input channel:

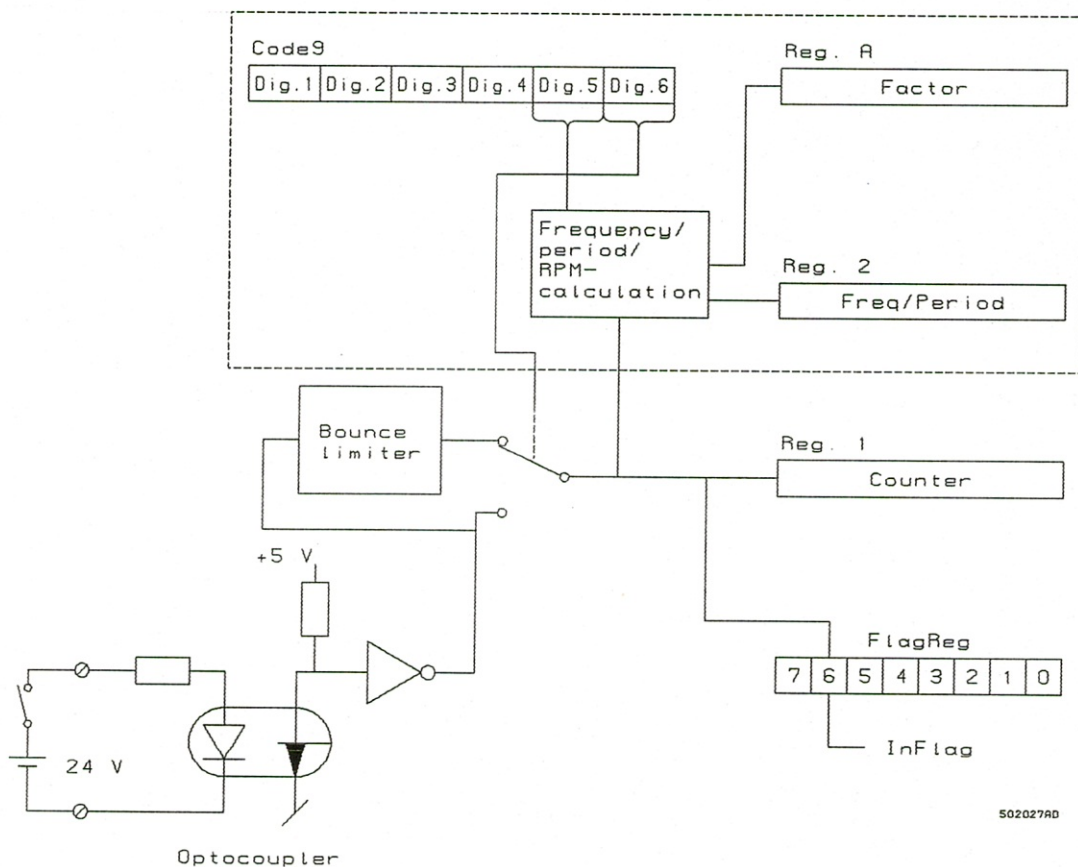

Registers in the Input Channel (channel 9).

Reg.no.	Register name	Write	Storage medium	Number of bytes	Read out
0	FlagReg Counter Frequency/Period	(X)	R	1	Binary
1			R	4	Decimal
2			R	4	Decimal
3					
4					
5					
6					
7					
8					
9	Code9	X	E	4	Hexadec.
A	Scale	X	E	4	Decimal
B					
C					
D					
E					
F	CHError		R	1	Hexadec.

Reg. 0: FlagReg

The input flag is set when a voltage is applied to the input terminal, and reset when the voltage is not present.

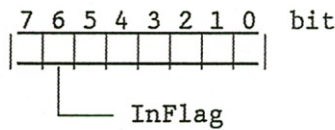

Reg. 1: Counter

The counter totalizes the number of pulses applied at the input. The frequency of counting is a maximum of 250 Hz. The counter counts up each time the InFlag shifts.

There is no automatic preset of the counter. If it is required to preset the counter, this must be performed using the P-net or the display unit.

Reg. 2: Freq/Period.

The measured result which can be a frequency or a period, can be read in register 2.

The input pulse frequency must be between 0.1 Hz and 250 Hz. If the frequency is below 0.1 Hz, register 2 will be set to 0.

New data is processed every two seconds, unless the pulse frequency is below 0.5 Hz. In this case the time between pulses is measured, and the frequency is calculated from this.

The accuracy of the reading is within about 0.1%.

Reg. 9: Code9.

Code register for the digital input channel (reg. 9).

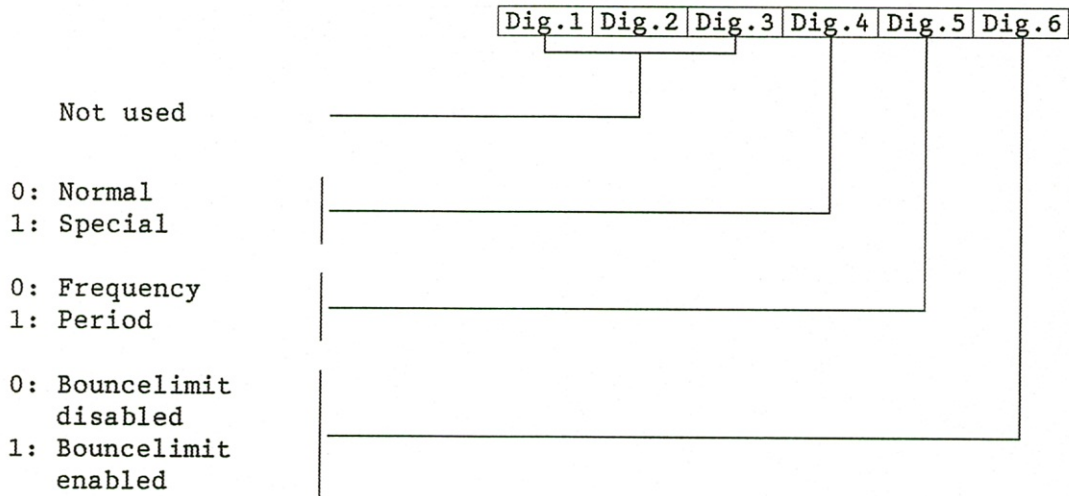

If the special function is on, data may be collected from a three-phase encoder (or even a three-phase pulse transmitter in a turbine flow meter). In this case each of the three pulse signals must be connected to a digital input (channel 9 - B).

The counter register (on channel 9) will be incremented or decremented depending on the flow direction. The frequency register (also on channel 9) will show the frequency, and the sign will indicate the flow direction.

Note: The FlagReg on the three input channels will not show anything reasonable as long as the special function is on.

More information on the special function can be obtained from **Proces-Data**.

The built-in switch bounce limiter function can be selected by digit 6. The switch bounce on the inputs can have a duration of up to 10 ms. When the function is selected the input frequency must not exceed 25 Hz.

With the bounce limiter de-selected
the minimum on and off time permitted is 2 ms.

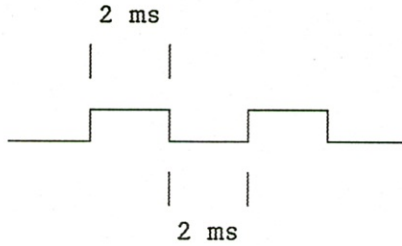

With the bounce limiter selected, the
minimum on and off time permitted is 20 ms.

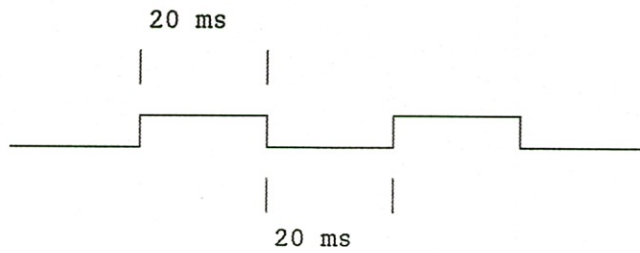

Digit 5 is used to select frequency or period.

Reg. A: Scale.

This register holds a factor which is always multiplied with the contents of register 2. If it is required to convert frequency to RPM, the factor should be $1/60 = 0.01667$ (if the pulsator gives 1 pulse per revolution). If a conversion is not required the factor should be set to 1.

Reg. F: CHError.

The error code shows whether there are any current errors in the module as a whole, which could result in this particular channel being faulty. The error code contains 8 bits of which only one is significant.

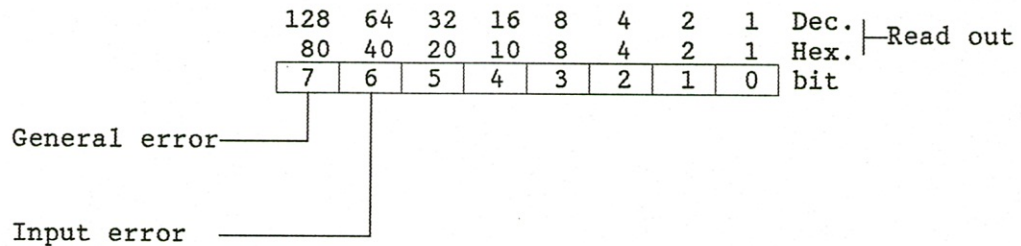

If bit 7 (General error) is set, the other bits are of no importance since the general error may cause any error code on the individual channels (see "Service Channel").

Bit 6 can only occur if a special function is enabled. This bit is set if there is a bad combination on the three digital inputs. (It is up to the user to cancel the input error, which can only be done via P-net. The input error bit will always be set, just after switching on the system.)

8. Simple input channels.

The PD 1652 module has 2 digital input channels (channel A and B).

The two digital inputs are constructed as passive inputs, i.e. the input must be powered from an external circuit (or from the built in voltage output). The input is galvanically separated from the rest of the electronics by means of an optocoupler and furthermore it is protected against overload when incorrect polarized.

Block diagram of input channel:

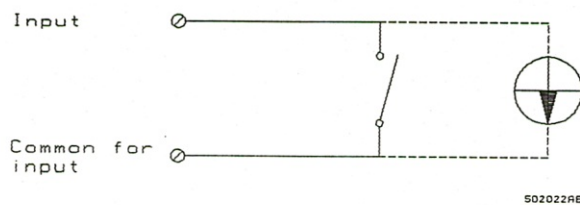

Registers on input channel (channel A-B).

Reg.no.	Register name	Write	Storage medium	Number of bytes	Read out
0	FlagReg Counter	(X)	R	1	Binary Decimal
1			R	4	
2					
3					
4					
5					
6					
7					
8					
9					
A					
B					
C					
D					
E					
F			CHError		

Reg. 0: FlagReg.

The input flag is set when a voltage is applied to the input terminal, and reset when the voltage is not present.

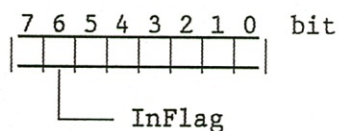

Reg. 1: Counter.

The counter counts the number of pulses on the input. The counter is incremented by one each time the InFlag shifts from "1" to "0".

Automatic preset of the counter is not available. The counter must be preset by means of a display unit or via the P-net.

Reg. F: CHError.

The error code shows whether there are any current errors in the module as a whole, which could result in this particular channel being faulty. The error code contains 8 bits of which only one is significant.

	7	6	5	4	3	2	1	0	bit
Bit 7: General error	X								

8.1. Detection of switch state, e.g. push-buttons, microswitches.

For this activity input channels (9-B) are used.

Mode of operation:

The switch state is indicated in the flag register for the selected input channel (reg. 0).

When the switch is closed the input flag is set.

When the switch is open the input flag is reset.

Connection to terminal block:

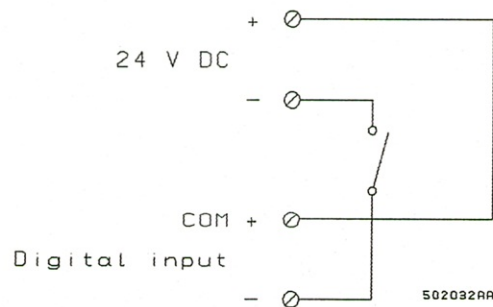

Using this arrangement, the counter (Reg. 1) will be incremented each time the switch is opened.

No special setting of the module is required.

9. Digital Output.

The transmitter is equipped with two digital output channels (channel C and D).

The two digital outputs have been configured as passive outputs, ie, the output works as a switch. Furthermore the output is galvanically separated from the other part of the electronics by means of an optocoupler.

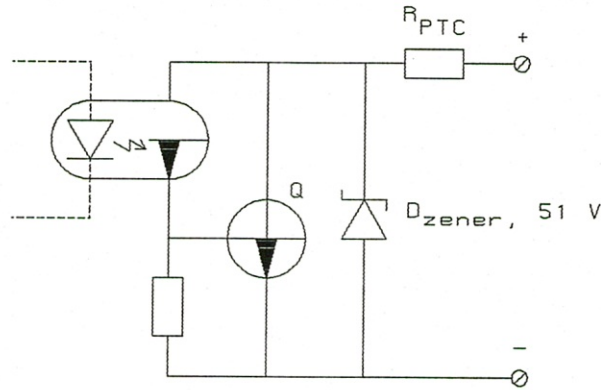

502024BC

Blockdiagram of Digital Output:

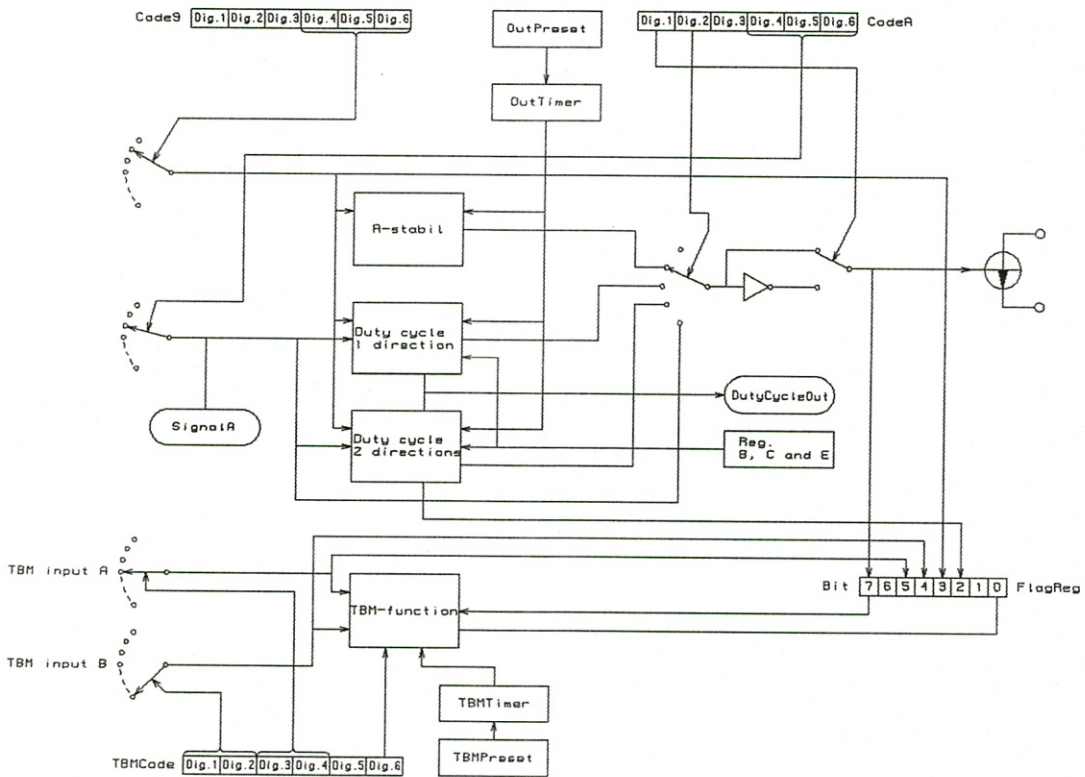

502025AE

9.1. Registers on Digital Output Channel.

Reg.no.	Register name	Write	Storage medium	Number of bytes	Read out
0	FlagReg	X	R	1	Binary
1	OutTimer	X	R	2	Decimal
2	DutyCycleOut		R	4	Decimal
3					
4					
5	SignalA *	X	BR	4	Decimal
6	TBMTimer	X	R	2	Decimal
7	TBMPreset	X	E	2	Decimal
8	OutPreset	X	E	2	Decimal
9	Code9	X	E	4	Hexadec.
A	CodeA	X	E	4	Hexadec.
B	FullScale	X	E	4	Decimal
C	ZeroPoint	X	E	4	Decimal
D	TBMCode	X	E	4	Hexadec.
E	MinTime	X	E	2	Decimal
F	CHError		R	1	Hexadec.

* Indirect register

Reg. 0: FlagReg.

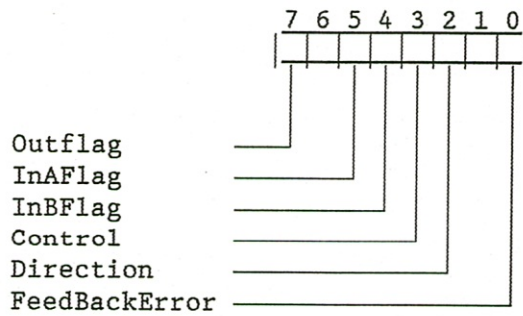

Bit 7: OutFlag.

The flag controls the output, provided that the watch dog flag is set or disconnected (by means of code register on service channel).

Flag = "0" == => Output OFF
Flag = "1" == => Output ON

Bit 5 and 4: InAFlag, InBFlag.

If feedback control on the output channel is required, one or two input channels must be used.

The InAFlag directly reflects the input flag on the channel chosen as channel A (by means of code register). Correspondingly the InBFlag will reflect the input flag on the channel chosen as channel B.

Bit 3: Control.

When the Control flag is set, the automatic functions chosen for the channel concerned are active.

When "0" is set in the Control Flag, the OutFlags are reset, and the automatic functions are disconnected (except the feedback control). The output can then be controlled normally. After starting, Control flag is reset.

Bit 2: Direction.

If one wishes to run duty-cycle regulation in two directions, it is possible to determine the direction by means of this bit.

Positive DutyCycleOut = Direction flag = "0"
Negative DutyCycleOut = Direction flag = "1"

Bit 0: FeedBackError.

This flag shows whether the feedback control, which might be connected, has detected a feedbackerror.

FeedBackError = "1" = error

Note: This feedbackerror can also be read in the error code register (Reg. F).

Reg. 1: OutTimer.

Each output channel has a timer, which is used for automatic control functions. The counter counts downwards at 10 Hz (maximum time approximately one hour), until it reaches the value 0.

The timer is preset either via P-net or from the preset register depending on which function has been chosen for the channel concerned.

Reg. 8: Outpreset.

This register contains a preset value for the timer, which is transferred by automatic controls.

Reg. D: TBMCode.

By means of this code register one can chose between the various feedback functions (which can be with single or double feedback).

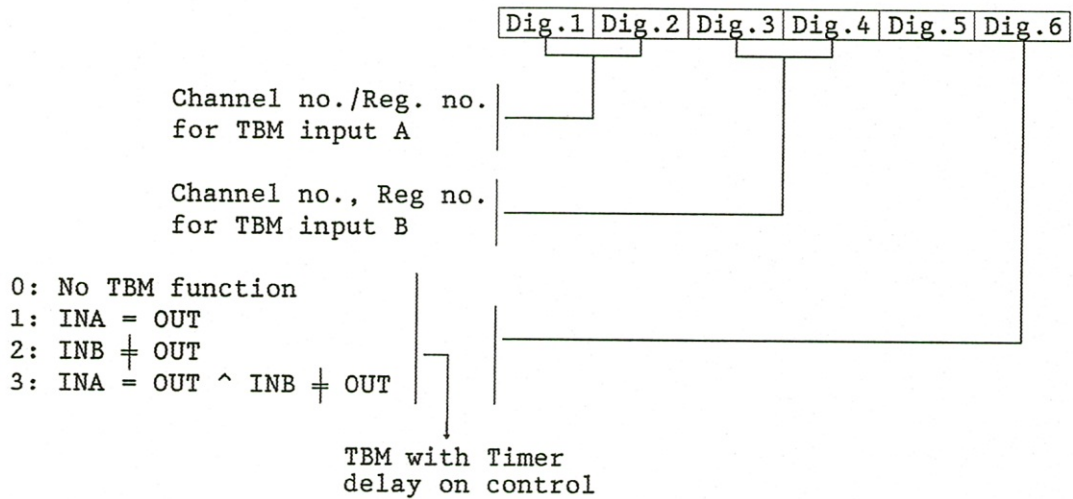
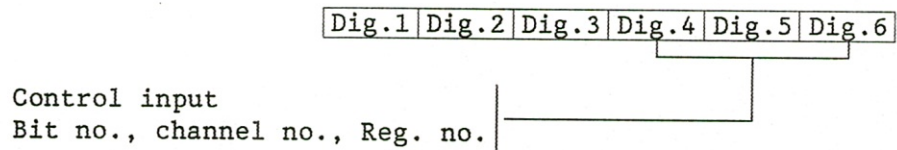
Reg. 9: Code9.

If it is required to control the control flag by means of another bit, for example an input flag on a digital input, this can be done by pointing to the selected bit, ie, bit number, register number and channel no number must be known. If this function is not required, then a 0 must be inserted in digits 4, 5 and 6.

Reg. A: CodeA.

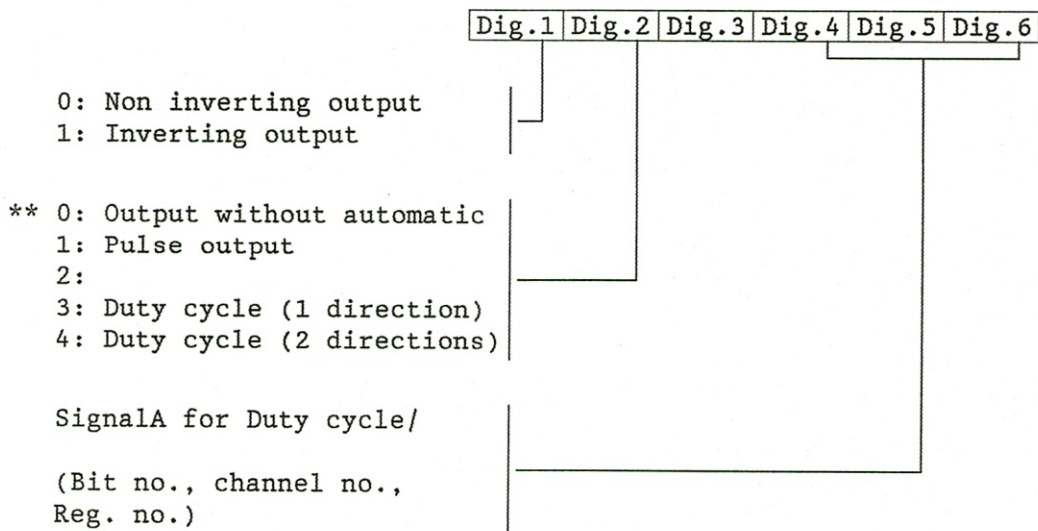

By means of digit 1, the output can be inverted. The Outflag, which normally follows the output will, however, not be inverted.

If one of the DutyCycle functions has been selected, only one channel number, and only one register number in the code register needs to be pointed to.

** These functions will be explained in more detail in the following sections.

Reg. 5: SignalA. *

SignalA which is selected by the code can be read in this register.

If the code register points to address 00, one can write in the register.

Reg. 6: TBMTimer.

Every output channel has a TBM-timer which detects the delay of the TBM-control.

The timer counts down at 10 Hz (max time approximately one hour) until it reaches the value 0.

The timer is preset either via P-net or from the corresponding preset register.

Reg. 7: TBMPreset.

This register contains a preset value for the TBM-timer, which is transferred during the automatic control.

Reg. 2: DutyCycleOut.

When the digital output is programmed as a duty cycle output, a value (0-100%) which the current can follow will automatically be calculated. This value defined the length of time the output must be on, as shown in the figure below.

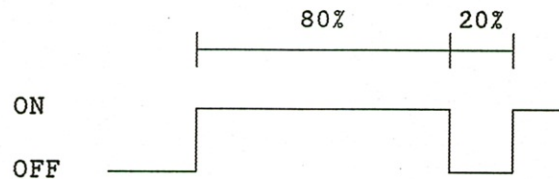

In this example, the output is ON for 80% of the time, ie, the DutyCycleOut register shows 80. The frequency of the output signal can be changed just by adjusting the contents of the OutPreset register (Reg. 8).

Reg. B: FullScale.

FullScale is the value of input signal which will result in a DutyCycleOut value of 100%.

Reg. C: ZeroPoint.

Zeropoint is the value of input signal which will result in a DutyCycleOut value of 0%. If a duty cycle output is run for two directions, ZeroPoint will be the value input signal which will result in a DutyCycleOut value of -100%.

Reg. E: MinTime.

The shortest time allowed for the output to be ON can be defined in this register. If the length of time which the output is ON should fall below the contents of the MinTime register, the output will go OFF. The minimum value is given in the same units as the OutPreset value.

Reg. F: CError.

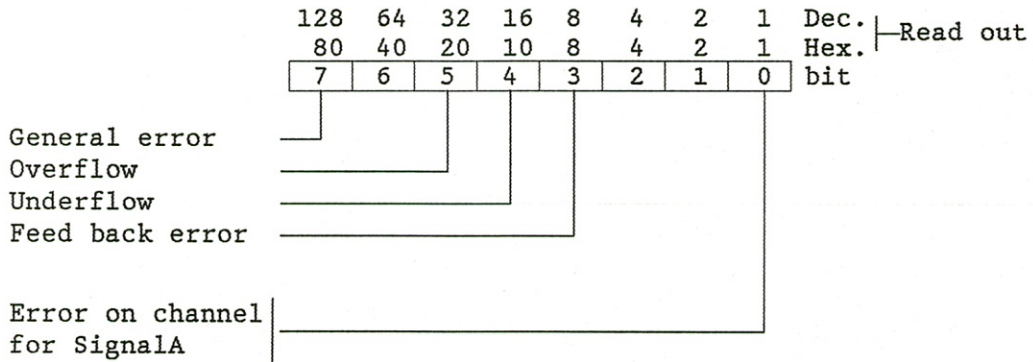

If bit (general error) is set, then the other bits are insignificant, as the general error can be caused by error codes on various other channels (see Service Channel).

Bit 5 (over flow) is set if the DutyCycleOut value exceeds 100%.

Bit 4 (under flow) is set if the DutyCycleOut value falls to below 0%. If, however, duty cycle output is being run with two directions, then bit 4 will be set if DutyCycleOut value falls to below -100%.

Bit 3 (feedback error) is set if a feedback error occurs (can also be read in FlagReg (Reg. 0)).

If bit 0 is set, then there is an error in the channel from which SignalA was fetched. The error can only occur if the digital output is programmed for a limit/batch function or for duty cycle output.

9.2. Output control via P-net.

Function:

Output is controlled by means of bit 7 (OutFlag) in the flag register of the output channel (Reg. 0). This flag is set/reset via P-net or display unit PD 230.

Output goes ON if OutputFlag **and** watch-dog flag are set. (If the watch-dog function is not to be used it may be cut off, see "Service Channel").

The OutFlag can be set/reset independent of the watch dog flag. The watch dog function is independent of the Control-flag. OutFlag will, however, be reset (output goes OFF) if the Control-flag is reset - even if the Control-flag has already been reset.

Timing diagram

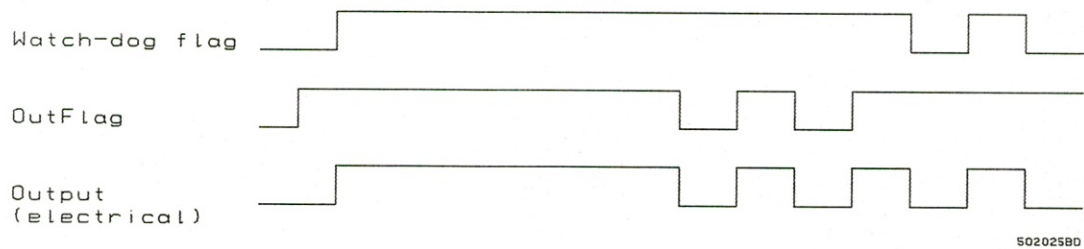

Note: The Watch-dog flag is an internal flag which can not be read out.

9.3. Output controlled via timer, (pulse output).

Method of operation:

If the Control-flag is set, the output will change every time the timer reaches 0.

(The period of time t_p is equal to twice the contents of the OutPreset register).

When the Control-flag is reset, the output is reset and can then be controlled via P-net. The timer (OutTimer) will still run even if the Control-flag is reset, but will not be preset when reaching 0.

When the Control-flag is set, the output will change immediately if the OutTimer is 0. If the OutTimer register is not 0, the output will change only when the OutTimer register is 0. The timer can be set to 0 via P-net before the Control- flag is set.

Timing diagram:

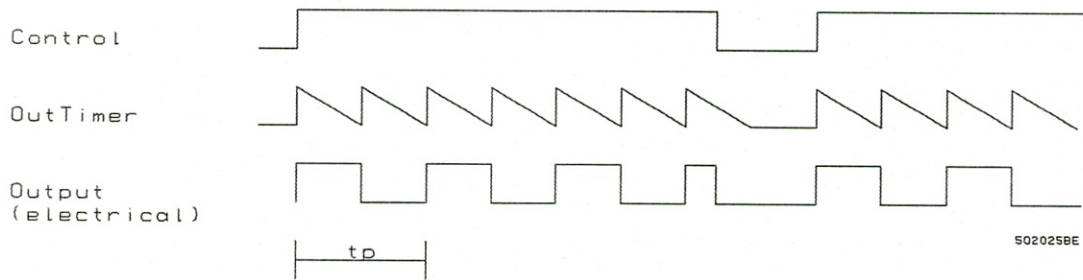

The period of time $t_p/2$ is inserted in 1/10 seconds in the timer-preset register (OutPreset) for the output channel (Reg. 8).

9.4. Sequence control.

The two digital outputs can be programmed to follow any bit in a flag register (or perhaps a bit in an error code register).

This is done by pointing to the bit selected, ie, bit number, register number and channel number must be known. This can be done as shown in the example below:

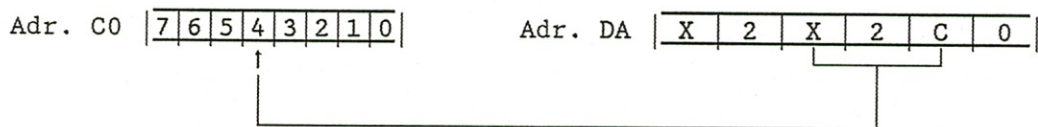

In the example, bit 2 on channel C in register 0 is pointed to, ie, the digital output (channel D) is set to follow the direction flag (bit 2) on the other digital output (channel C).

9.5. Single feedback (TBM) with variable delay.

For this TBM function 1 output is used.

Method of operation:

When the output changes, then the input must change within the time $t_{d\ max}$. If this does not happen, then the FeedbackError is set in the flag register for the output-channel (Reg. 0).

The delay of the TBM control ($t_{d\ max}$) is inserted into the TBMPreset register for the output channel (Reg. 7).

Connection to terminal strip:

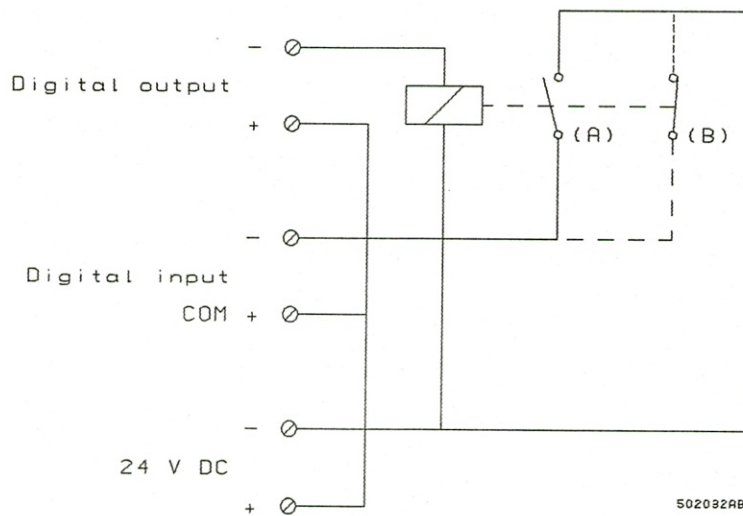

Timing diagram:

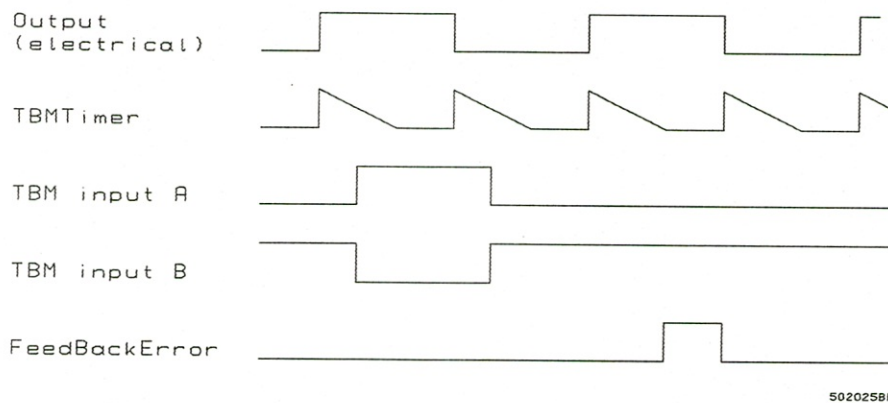

For single feedback input channel (9 -B) is used.

In order to achieve a single feedback function, the code register (Reg. D) must be programmed as follows:

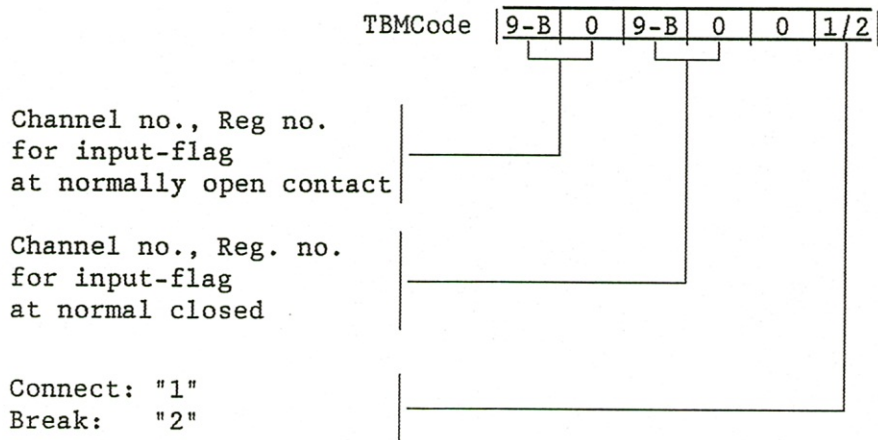

9.6. Double feed-back signal with variable delay.

For double feedback two input channels are used (9 and A) in addition to the output channel. The normally "open" switch is connected to channel 9, and the normally "closed" switch to channel A.

Method of operation:

When the output is OFF, input 9 must be reset (open switch) and input A must be set (closed switch). The maximum delay allowed for the TMB control ($t_{d\ max}$) is inserted in the timer-preset register for the output-channel (Reg. 7). When the output changes both input 9 and input A must change within the time $t_{d\ max}$. If this does not happen, a FeedbackError is set in the flag register for the output-channel (Reg. 0).

Connection to terminal strip:

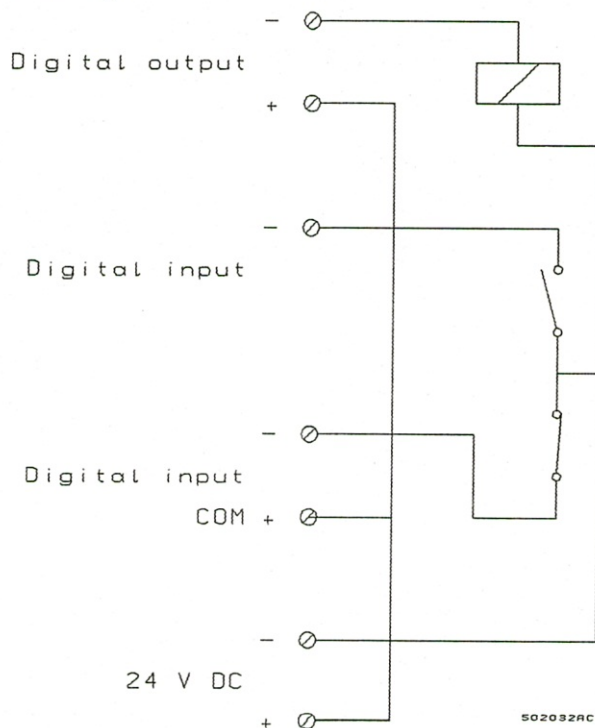

Timing diagram:

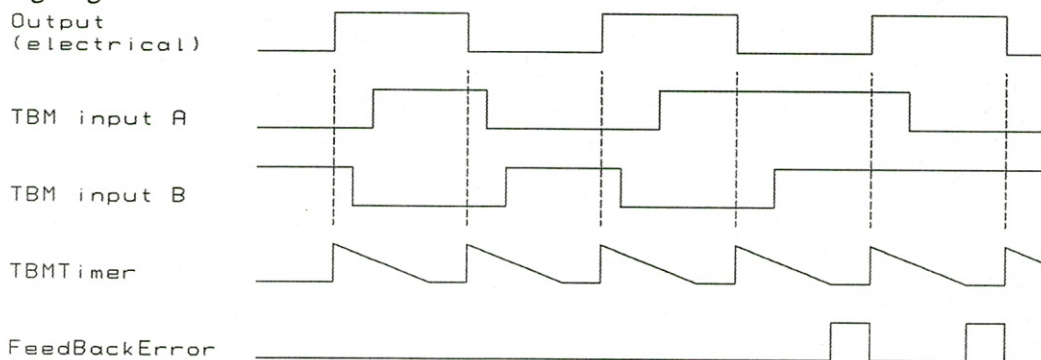

The associated input channels are 9 and A.

The code register for the output channel is set as follows:

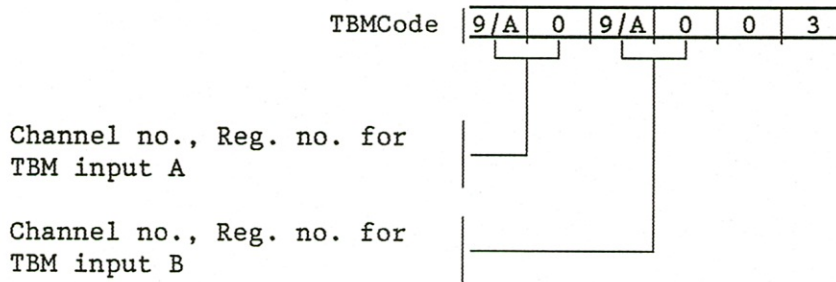

9.7. Feedbacks.

With one output, single or double feedback control (TBM) can be used.

If a feedback signal is used, the output must be associated with an input channel.

If two TBM signals are used, two inputs are connected.

The maximum delay allowed in the connected system without a FeedbackError occurring, is variable.

The setting of the output channel's code register is dependant upon whether the feedback switches used are normally closed contacts, or normally open contacts.

A normally open contact is a switch which is open when passive.

A normally closed contact is a switch which is closed when passive

When a normally open switch is being used, the input flag's channel and register number is inserted into the code register (Reg. D) in digit 1 and 2 (TBM Input A).

When a normally closed switch is being used the input flag's channel and register number is inserted into digit 3 and 4 (TBM Input B).

9.8. Controlling of Control-flag.

The module is equipped with a function that will set/reset the Control-flag automatically. This is done by pointing to a bit in a register. Ie, it is possible to connect or disconnect the digital output and the automatic functions, eg, by means of a digital input. This function will be especially useful if the multifunction module is located in a system in which the user has neither a display unit (PD 230) nor a computer connected. Then it would be possible to stop, for example, a batch by means of a switch, connected to a digital input.

Example:

If it is required to set/reset the Control flag by means of a digital input, this can be done by pointing to the InFlag in the flag register on the digital input channel, as shown below:

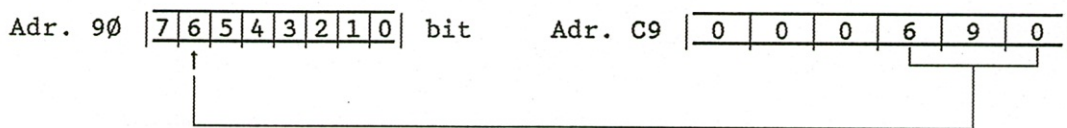

If the module is programmed as shown, the control flag will follow the input flag on the digital input channel.

Note: The Control flag can also be set directly in the flag-register (Reg. 0) by means of P-net or display unit (PD 230).

9.9. Duty cycle regulation.

It is possible to control the mark-space ratio of a digital output, for example, by means of a measured result on an analog input.

There are two types of duty cycle regulation, either regulation in one direction or regulation in two directions.

9.9.1. Duty cycle output in one direction.

This type of control can, for example, be used in conjunction with the internal PID-regulator for controlling of ON/OFF valve. This type of control is carried out by varying the ON-time on the output signal, but with a fixed defined frequency. The value which the output follows can be read in the DutyCycleOut register, and the value will be calculate as follows:

$$\text{DutyCycleOut} = \frac{\text{Input signal} - \text{ZeroPoint}}{\text{FullScale} - \text{ZeroPoint}} \times 100$$

- ie the DutyCycleOut value will always be 0-100%.

9.9.2. Duty cycle regulation in two directions.

Duty Cycle output in two directions can, for example, be used for controlling a bi-directional motor. The control is carried out by varying the ON-time of the output signal. The value which the output follows, can be read in the DutyCycleOut register, and the value is calculated as follows:

$$DutyCycleOut = 2 \times \left(\frac{SignalA - ZeroPoint}{FullScale - ZeroPoint} - 0,5 \right) \times 100$$

- ie the DutyCycleOut value will always be in the region of "zero" (DutyCycleOut will be between -100 - 100%). The Direction flag (Reg. 0) will show the sign.

DutyCycleOut Positive = Direction bit = 0
 DutyCycleOut negative = Direction bit = 1



5020248K

The Duty Cycle output can run with a resolution of 120 ms, the resolution will, however, fall to 240 mS if both digital outputs are programmed as duty cycle output.

10. Service Channel (Channel 0).

The service channel contains registers which are relevant to all other channels. The service channel contains data about the module type and version No. of the program, both types of data being important to the P-net operation. The service channel monitors the microprocessor, collects error codes from other channels, and also controls the monitor facility called a watch-dog.

In the case of external errors, (for example a break in the communication cable, or a loss of supply voltage in the control computer) this would result in the module not being called by the P-net, and the Watch-dog will automatically inhibit all outputs, and cause the current output to decrease to 4 mA.

The user is able to decide how much time there should be between call-ups to the module via P-net. If this time is exceeded the watch-dog facility comes into operation as described above. At the same time, an error will be registered in the general error code register and in the error code registers for the other channels.

Registers in the Service Channel.

Reg.no.	Register name	Write	Storage medium	Number of bytes	Read out
0					
1	DeviceType		P	2	Decimal
2	PrgVers		P	2	Decimal
3	Error3	X	R	1	Hexadec.
4					
5					
6					
7	WDTimer	X	R	2	Decimal
8	WDPreset	X	E	2	Decimal
9	Code9	X	E	4	Hexadec.
A					
B					
C					
D					
E					
F	ErrorF		R	1	Hexadec.

Reg. 1: Device Types

This register contains the module type number, e.g. 1652.

Reg. 2: PrgVers

This register contains the program version number, e.g. 8601

Reg. 3: Error3

This register contains the highest error code detected since the last error code register reading. Even if the error was transitory, the code will be retained until the register is interrogated. The error code meanings are the same for register 3 and register F.

By inserting an FF in the register, the module will carry out a Reset.

Reg. 7: WDTimer

When the module is communicated with via P-net, the timer is automatically set to the value from the preset register (reg.8). If the timer reaches zero before it is set again, the watch-dog flag will be reset, causing the outputs to switch OFF and the current output to revert to 4 mA.

Reg. 8: WDPreset Register

The maximum time allowed between two call-ups to the module, without the watch-dog being activated, is set in this register.

Reg. 9: Code 9

This register enables the watch-dog facility to be selected.

The register contains 6 digits.

Digits 1-5 are not used.

Digit 6 defines whether the watch-dog is selected or not.

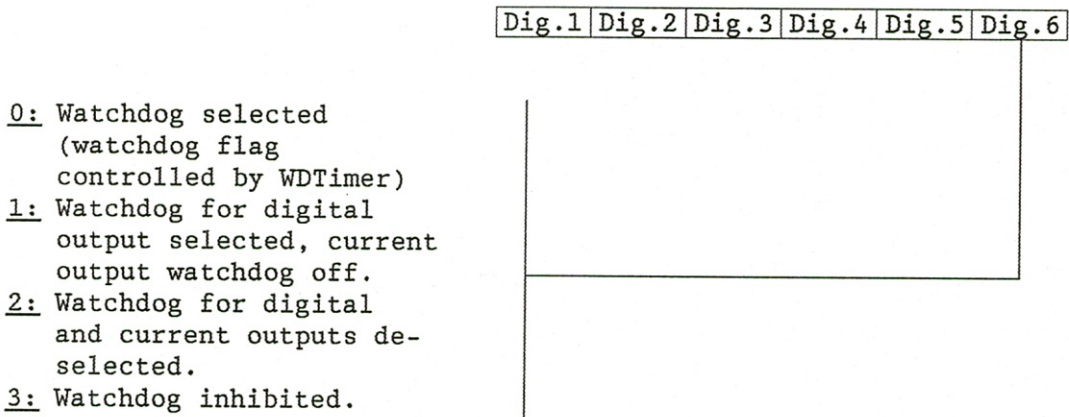

Register F: ErrorF

When faults occur, this error code register will contain the last error code while the fault exists, but if the fault disappears the code will not be retained in the register (unlike register 3).

The error code register contains 8 bits which need to be converted to a (hexadecimal) number between 0 and 93.

The error codes can be split into two groups. Numbers below 80 pertain to errors on individual channels, and 80-93 apply to errors on the module as a whole.

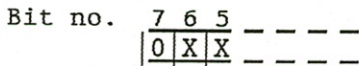

If the most significant bit (bit7) is "0", then an error only applies to a single channel.

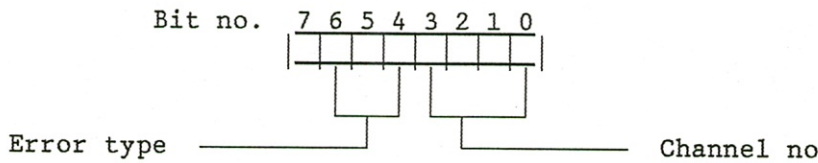

Channel 1 & 2:

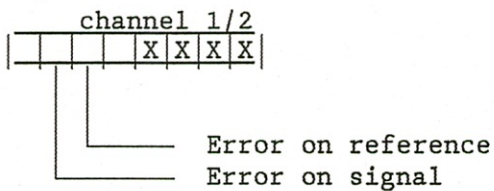

Channel 3 & 4:

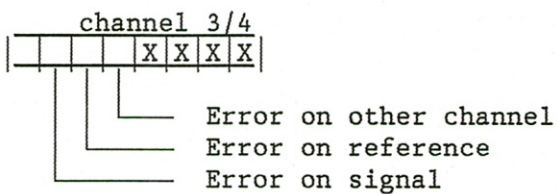

Channel 5:

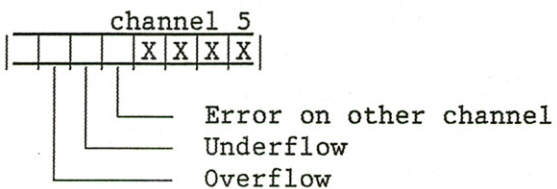

Channel 6:

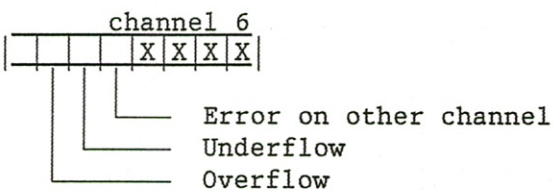

Channel 7 & 8:

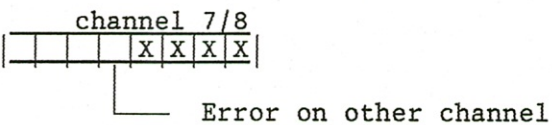

Channel 9:

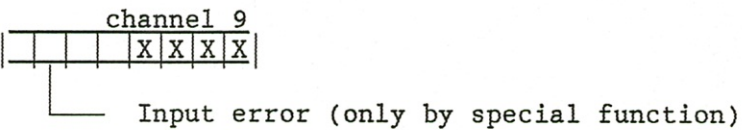

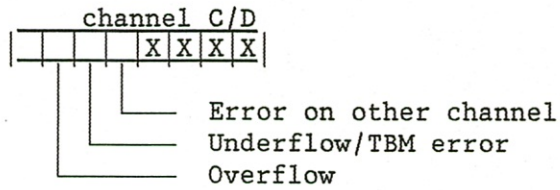
Channel C & D:

* cannot be read via display unit PD 230.

If further information on the error is required, register F on the specific channel can be read.

Bit no. 7 6 5 _ _ _ _
 | 1 X X _ _ _ _

If the most significant bit (bit 7) is "1" then one of the error codes 80-93 applies.

These error codes (read as hexadecimal numbers) have the following meaning:-

<u>Error Codes</u>	<u>Meaning</u>
80	Voltage output overloaded
85	WDTimer run out
89	External data-storage fault.
90	Program cycle time fault (microprocessor short of time)
91	Write protected data storage fault.
92	Internal data storage fault.
93	Program storage fault.

11. Display Channel (Channel E).

The display-unit, PD 230, can be directly connected to all of the PROCES-DATA series of modules. Thus it is possible to display or change any register in a module. Moreover, it is possible to both display and modify up to 8 different registers, simply by pressing one of the 8 keys K1 to K8 on the display unit.

However, it is important to note that data, except for a code register, is displayed in decimal format. Therefore, if it is required to display a flag register, this will be displayed in decimal and not in hexadecimal format.

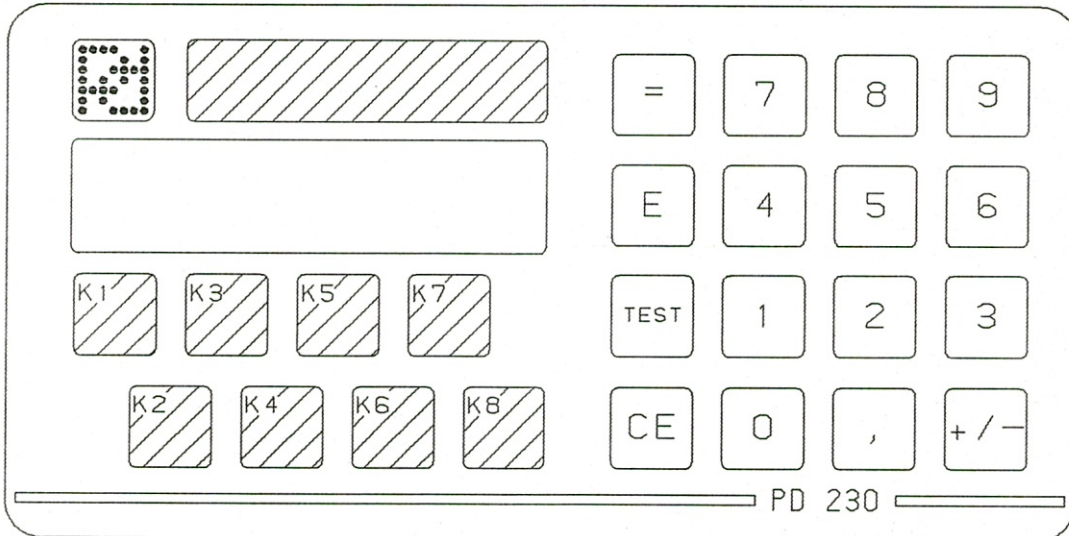

502024AA

Note: The shaded areas illustrate transparent screens, behind which customised text can be placed.

Reg.no.	Register name	Write	Storage medium	Number of bytes	Read out
0					
1	Code1	X	E	4	Hexadec.
2	Code2	X	E	4	Hexadec.
3	Code3	X	E	4	Hexadec.
4	Code4	X	E	4	Hexadec.
5	Code5	X	E	4	Hexadec.
6	Code6	X	E	4	Hexadec.
7	Code7	X	E	4	Hexadec.
8	Code8	X	E	4	Hexadec.
9					
A					
B					
C					
D					
E					
F					

To enable the programming of the PD 1652 module using the display unit, it is possible to modify the code register and other write protected registers (i.e. all registers with an E for storage medium in the register definition). A write-protected register is displayed by keying in E1, followed by the channel and the register number - eg:-

Fullscale on channel 1 needs to be modified:

Key	Read out	
$\overline{E} \mid \overline{1}$	0	
$\overline{1} \mid \overline{1} \mid \overline{1} \mid \overline{1}$	0111	
$\overline{=}$	1B	Channel no., Reg. no.
$\overline{K1}$	100,000	FullScale = 100
$\overline{2} \mid \overline{0} \mid \overline{0}$	200	FullScale is altered from 100 to 200.
$\overline{=}$	200,000	FullScale is saved in write protected store

Note: The letters A-F are keyed in as numbers. The display unit will then convert them to letters (hexadecimal notation) for display e.g. 12 corresponds to C.

The display unit has the following characters:

0: $\overline{0}$	8: $\overline{8}$
1: $\overline{1}$	9: $\overline{9}$
2: $\overline{2}$	A: \overline{A}
3: $\overline{3}$	B: \overline{B}
4: $\overline{4}$	C: \overline{C} *
5: $\overline{5}$	D: \overline{D} *
6: $\overline{6}$	E: \overline{E}
7: $\overline{7}$	F: \overline{F}

502024BH

* Note these characters, as they are rather unusual.

11.1. An example of programming a display channel via the PD 230 display unit.

Output in % on channel 5 is to read by pressing display channel 2 key (K2):

Key	Read out	
$\overline{E} \overline{1}$	0	
$\overline{1} \overline{4} \overline{0} \overline{2}$	1402	
$\overline{=}$	E2	Channel no., Reg.no.
$\overline{K1}$	000000	Display code 2

Thereafter the code can be written by altering one digit at a time.

This is done by pressing the display channel key (KX) below the digit to be altered.

$\overline{K3}$	0	
$\overline{5}$	5	0 is altered to 5 in digit 1.
$\overline{=}$	5	5 = channel no. of value read out.
$\overline{K1}$	500000	Display code 2
$\overline{K8}$	0	
$\overline{3}$	3	0 is altered to 3 in digit 6.
$\overline{=}$	3	3 = 3 digits after decimal point.
$\overline{K1}$	500003	Display code 2
$\overline{E} \overline{1}$	E2	
$\overline{0}$	0	
$\overline{=}$	0	Back to read out mode.
$\overline{K2}$	56,555	Output in % on channel 5.

Output in % on channel 5 is thus read with 3 digits after the decimal point.

11.2. Programming of the function keys (K1-K8).

To choose up to 8 registers selected by the keys below the screen (K1-K8), the module must be programmed. This is done by using the eight display-code registers in the display channel. There is a code register for each key below the screen (K1-K8). This means that the user can define a specific register for display associated with each channel.

Note: The code register cannot be displayed or changed by this method.

Reg. 1: Code 1

Channel no.,
Reg. no. for
out/input value
from K1

Number of digits after
decimal point (0-6)

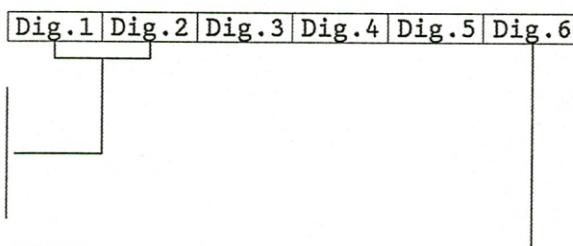

Reg. 2: Code 2

Channel no.,
Reg. no. for
out/input value
from K2

Number of digits after
decimal point (0-6)

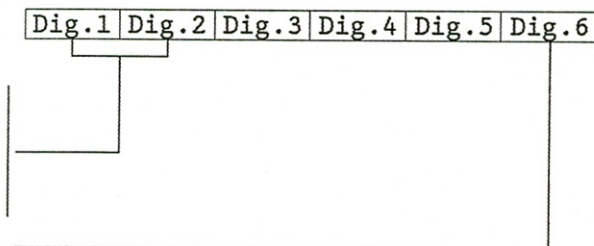

The address of the register required to be displayed or changed is stored in digit 1 and 2.

Digit 6 is used for selecting the number of digits that should follow the decimal point on the displayed value.

Note: If an undefined address is being selected the display unit will show 999999 on the display.

11.3. Displaying error codes.

The PD 1652 is equipped with an extensive self testing system, which can detect faults caused by the module being wrongly used, or within in the module itself.

When the testing routines detect a fault, the user will be advised of this on the display unit, by means of an "A" for Alarm in the first digit of the display. By pressing the TEST key, the display will show an error code of 2 digits, indicating the nature of the fault (see section 8 "Reg. F: Error F").

The test system is designed so that the alarm is statized even if the fault disappears. The error code on the display is updated only by pressing the TEST-Key. If several errors occur at once, only the error code with the highest value is retained.

Note: The display can only present error codes on channel 1-6.

11.4. Connecting the PD 230.

The display unit is connected to the PD 1652 with a single 2 core cable. The display unit is powered through this cable, and exchange of data between PD 1652 and PD 230 also uses this medium. The length of the cable must not exceed 100 m and the cross sectioned area must be at least 0.75 sq.mm.

The cable is attached to the two spade connectors on the back of the display unit and to terminals 1 and 3 on the PD 1652's circuit board.

Terminal 1 should be connected to the spade connector marked "+".

11.5. Assembly drawing, PD 230.

The display unit PD 230 is designed for fixed positioning, eg, on a panel (see diagram).

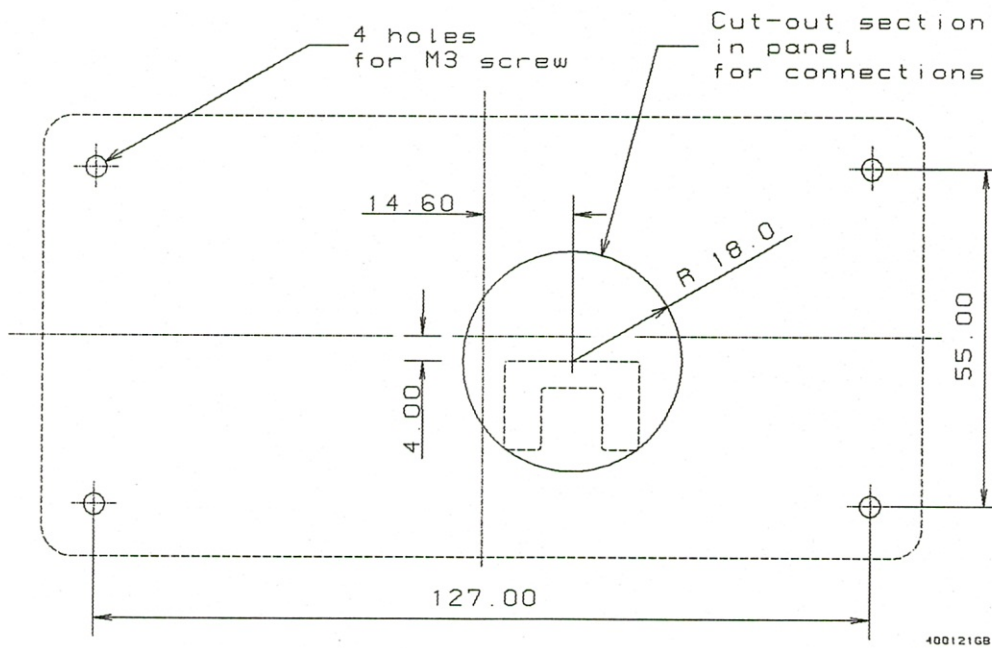

The dimensions of the display unit are:

H x L x W = 8 x 144 x 72 mm.

The unit is watertight and tolerates ambient temperatures between -10 °C and +50 °C.

12. Voltage Output.

The PD 1652 module is equipped with a voltage output which provides 24 V DC, at 150 mA maximum.

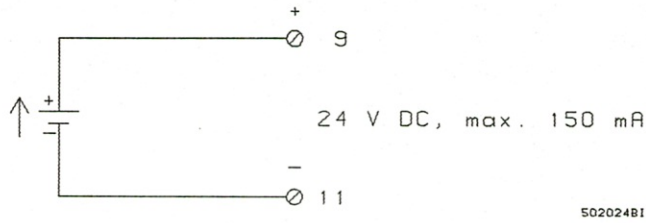

Fig. 12.a.

The voltage output can be used to supply external DC-equipment.

The voltage output is protected against overloading by a zenerdiode and a current limiting resistor.

Should an overload occur it will result in an error being stored in the error code register.

Following an overload the load should be removed before the output can be used again.

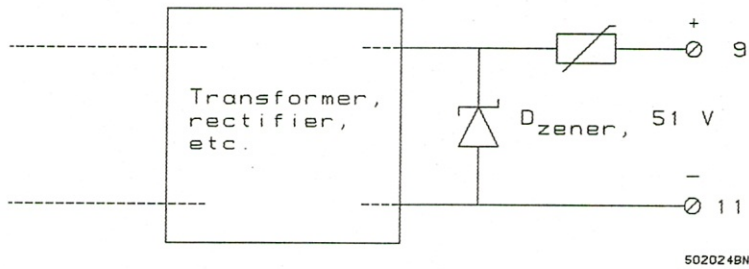
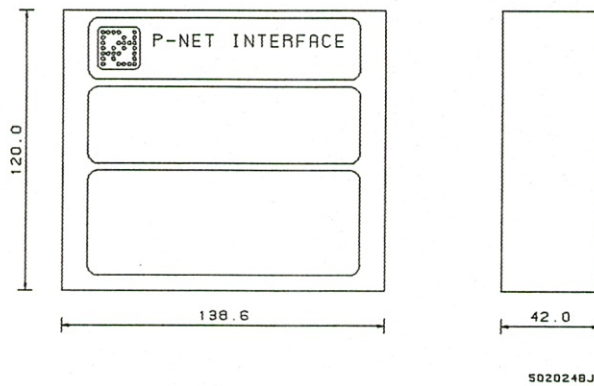

Fig.12.b. Voltage Output.

13. Construction, Mechanical.

The PD 1652 module consists of two circuit boards housed in an aluminum case. The case measures $W \times H \times D = 138.6 \times 120 \times 42$ mm.

Fig.13.a: Aluminum Case for PD 1652



The module is intended for mounting on a base circuit board, PD 1081 (Fig 12.b) where the interface terminals and the switch "Program Enable" are placed. PD 1080 base circuit board is the same for all the modules in PD's module series and measures $W \times H = 142 \times 150$ mm.

Fig 13.b: Base circuit board PD 1080

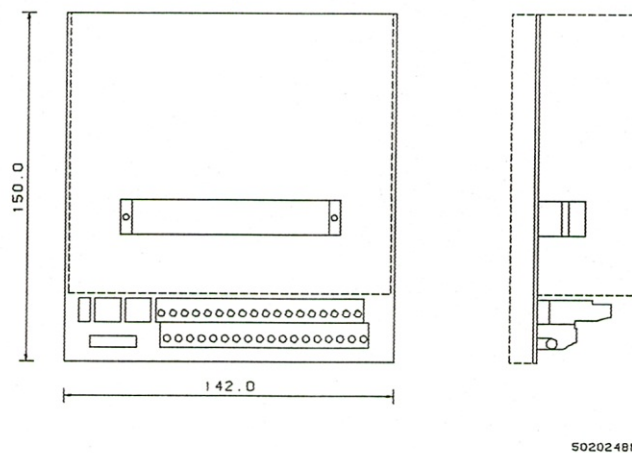

The connection between the module and the base circuit board is performed by plug and socket. The module can thus be changed without having to disconnect the wiring.

Apart from the terminals and the program enable switch, the base circuit board contains 2 rotary switches, which are used for setting the address of the module for the P-Net. The number applies to the base circuit board, and therefore need not be set again if a module is changed.

The module, with base circuit board, is designed for installing in either a sealed box for wall mounting or for incorporation in a cabinet with other equipment.

13.1. Connections.

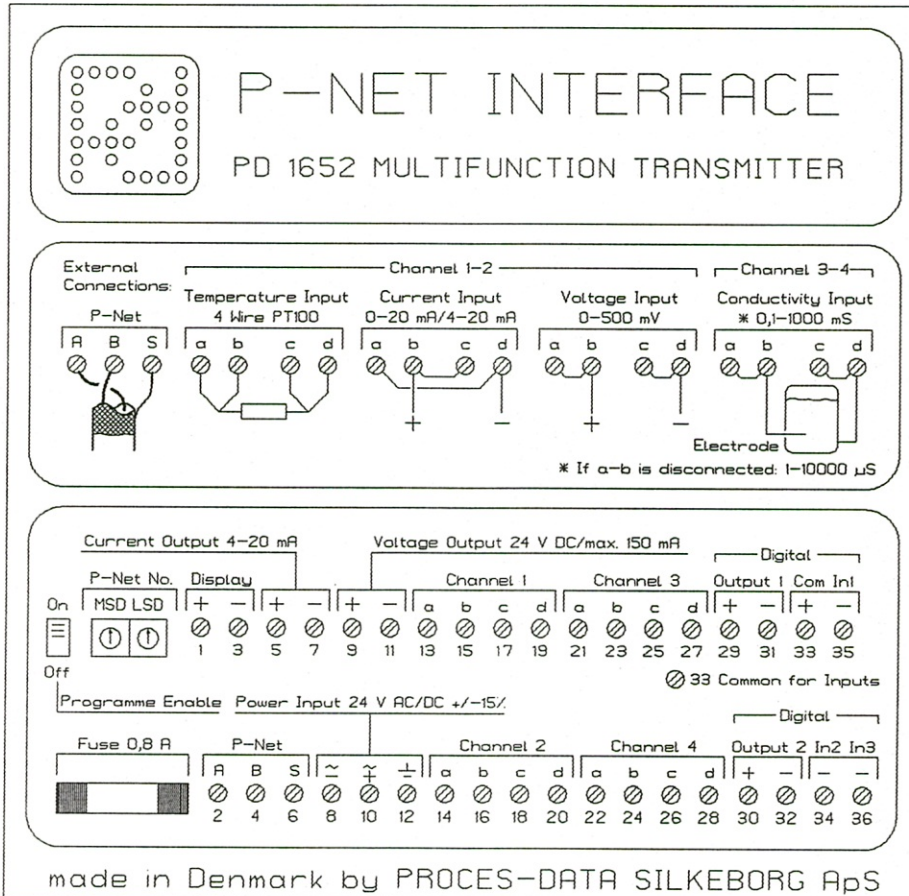

14. Specifications.

	Min.	Typical	Max.	Units
Power supply	20,4	24	27,6	V AC/DC
Power consumption	2,9		7,8	W
Current input:				
Deviation			±0,3	%
Repeatability			0,01	%
Impedance			0,02	%
Impedance			100	Ω
Voltage input (0-500 mV):				
Deviation			±0,3	%
Resolution			0,01	%
Repeatability			0,02	%
Impedance	1			MΩ
Temperature input with Pt-100 detector (DIN 43760)				
Deviation			±0,9	°C
Resolution			0,05	°C
Repeatability			0,1	°C
Temperature range	-30		400	°C
Loss of effect in temp. detector			0,1	mW
Conductivity input (1-10000 μS)				
Deviation when conductivity is				
1 μS			±14,7	%
10 μS			±1,3	%
100 μS			±0,17	%
1000 μS			±0,26	%
10000 μS			±2,8	%

To be continued..

	Min.	Typical	Max.	Units
Conductivity input (0.1-1000 mS)				
Deviation when conductivity is 0,1 mS			±0,46	%
1 mS			±0,16	%
10 mS			±0,34	%
100 mS			±3,9	%
1000 mS			±17,5	%
Digital input:				
Input voltage at "0"	0		6	V DC
Input voltage at "1"	18		30	V DC
Input-current when input voltage = 0			5	mA
Frequency range at 50% duty cycle	0		250	Hz
Deviation at 50% duty cycle			±0,3	%
Pulse time with bounce-limiter *	2			ms
Pulse time without bounce-limiter*	20			ms
Digital output:				
Voltage drop over output at 10 mA		1,709		V DC
Voltage drop over output at 100 mA		3,85		V DC
Current during load			100	mA
Voltage output				
Output voltage at 0 mA	24	26	28	V DC
Output voltage at 100 mA	21,5	23,5	25	V DC
Output current			150	mA
Ambient temperature	0		50	°C

* Pulse time = T_p

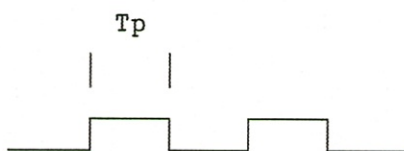

15. Noise limiter.

In environments with a high level of noise it is recommended to insert a hum eliminator before the supply transformer.

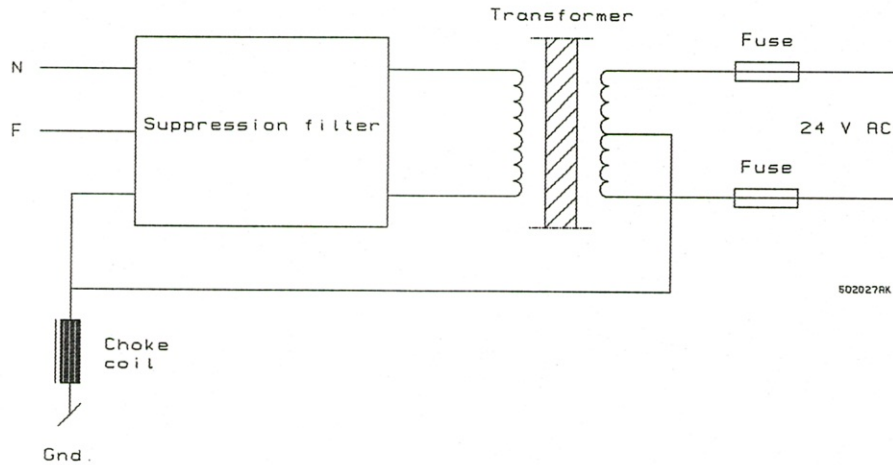

The hum eliminator could be a Schaffner FN332-1/05.

Also a hum eliminator with built-in impedance coil may be used.

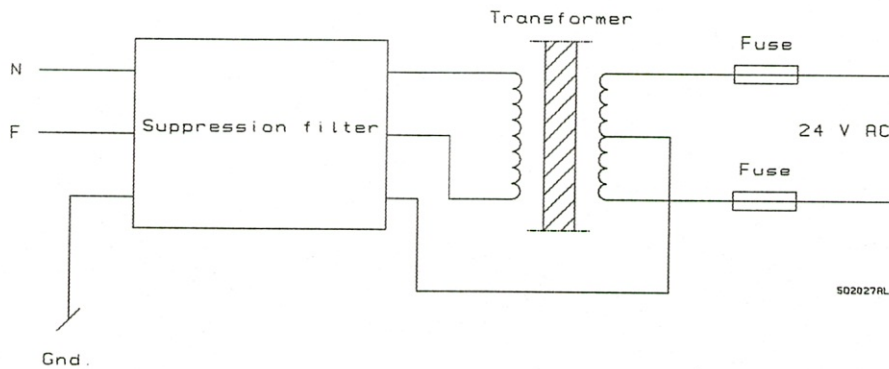

The hum eliminator could be a Schaffner FN343-1/05.

Because of the centre tap on the transformer, two fuses are necessary. If the + or - terminals are short circuited a large current will be produced, because the voltage is ± 12 V relative to ground.

It is recommended to use a two-chamber transformer with the primary winding in one chamber and the secondary winding in the other chamber.

16. Survey of registers in the PD 1652 module.

Reg. no.	Service channel 0	Analog input 1-2	Conductivity channel 3-4	Current output 5	PID-regulator 6	Dosing channel 7-8	Digital input 9-A	Digital output B-C	Display channel D
0		AnalogIn	CondIn	AnalogOut	Output	FlagReg	FlagReg	FlagReg	
1	DeviceType		CondDiff**		Signal1	Actual1	Counter	OutTimer	Code1
2	PrgVers				Signal2			DutyCycle	Code2
3	Error3		TCtemp		Actual				Code3
4									Code4
5						ActOffset1		SignalA	Code5
6						ActOffset2		TBMTimer	Code6
7	WDTimer			SetPoint	SetPoint	Actual7		TBMPreset	Code7
8	WDPreset				FlagReg8			OutPreset	Code8
9	Code9	Code9	Code9	Code9	Code9	Code9		Code9	
A			MaxDiff *		CodeA	CodeA		CodeA	
B		FullScale	FullScale	FullScale	Xp			FullScale	
C		ZeroPoint	ZeroPoint	ZeroPoint	Ti			ZeroPoint	
D			MaxDelta		Td			TBMCODE	
E			TempCoeff					MinTime	
F	ErrorF	CHError	CHError	CHError	CHError	CHError	CHError	CHError	

* Only on channel 4

** Only on channel 3

17. Survey of standard identifiers in the PD 1652 module for use in Process-Pascal.

Name	Register no.	Number of bytes	Storage medium	Read out	Channel no.
ActOffset1	5	4	BR	Decimal	7-8
ACtOffset2	6	4	BR	Decimal	7-8
Actual	3	4	R	Decimal	6
Actual1	1	4	BR	Decimal	7-8
Actual7	7	4	BR	Decimal	7-8
AnalogIn	0	4	R	Decimal	1-2
AnalogOut	0	4	R	Decimal	5
CHError	F	1	R	Hexadec.	1-D
Code1	1	4	E	Hexadec.	E
Code2	2	4	E	Hexadec.	E
Code3	3	4	E	Hexadec.	E
Code4	4	4	E	Hexadec.	E
Code5	5	4	E	Hexadec.	E
Code6	6	4	E	Hexadec.	E
Code7	7	4	E	Hexadec.	E
Code8	8	4	E	Hexadec.	E
Code9	9	4	E	Hexadec.	0-8, C-D
CodeA	A	4	E	Hexadec.	6-8, C-D
CondDiff	1	4	R	Decimal	3
CondIn	0	4	R	Decimal	3-4
Counter	1	2	R	Decimal	9-B
DeviceType	1	2	P	Decimal	0
DutyCycleOut	2	4	R	Decimal	C-D
Error3	3	1	R	Hexadec.	0
ErrorF	F	1	R	Hexadec.	0
FlagReg	0	1	R	Binary	7-D
FlagReg8	8	1	R	Binary	6
FullScale	B	4	E	Decimal	1-5, C-D
MaxDelta	D	4	E	Decimal	3-4
MaxDiff	A	4	E	Decimal	4
MinTime	E	2	E	Decimal	C-D
OutPreset	8	2	E	Decimal	C-D
Output	0	4	R	Decimal	6
OutTimer	1	2	R	Decimal	C-D
PrgVers	2	2	P	Decimal	0
SetPoint	7	4	BR	Decimal	5-6
SignalA	5	4	BR	Decimal	C-D
Signal1	1	4	BR	Decimal	6
Signal2	2	4	BR	Decimal	6
TBMCode	D	4	E	Hexadec.	C-D
TBMPreset	7	2	E	Decimal	C-D
TBMTimer	6	2	R	Decimal	C-D
TCTemp	3	4	BR	Decimal	3-4
Td	D	4	E	Decimal	6
TempCoeff	E	4	E	Decimal	3-4
Ti	C	4	E	Decimal	6
WDPreset	8	2	E	Decimal	0
WDTimer	7	2	R	Decimal	0
Xp	B	4	E	Decimal	6
ZeroPoint	C	4	E	Decimal	1-5, C-D

17.1. Survey of standard identifiers (Bit).

Name	Register no.	Bit no.	Channel no.
BatchFlag1	0	5	7-8
BatchFlag2	0	6	7-8
Control	0	3	C-D
Direction	0	2	C-D
EORFlag	0	0	7-8
FeedbackError	0	0	C-D
Handshake	0	7	7-8
InAFlag	0	5	C-D
InBFlag	0	4	C-D
InFlag	0	6	9-B
Manual	8	0	6
OutFlag	0	7	C-D

Contents, alphabetically.

An example of programming a display channel via the PD 2	80
Analog Input Channels	7
Assembly drawing, PD 230	83
Batch run.	49
Block diagram of Analog Input Channels	7
Block Diagram of Conductivity Channels	14
Block diagram of PD 1652	2
Calculation of Actual Value	32
Channels/registers	3
Combining Channels	6
Conductivity Inputs	14
Conductivity measurement with one electrode	20
Conductivity measurement with two electrodes	20
Connecting the PD 230	82
Connection to analog input channels	11
Connection to P-NET	2
Connections	86
Construction, Mechanical	85
Controlling of Control-flag.	71
Current measurement, 0-20 or 4-20 mA.	11
Current Output	21
Current Output, Electrical.	25
Description of error codes on channel 1 and 2.	10
Detection of switch state, e.g. push-buttons, microswitc	57
Digital Output	58
Display Channel (Channel E)	78
Displaying error codes.	82
Double feed-back signal with variable delay.	69
Duty cycle output in one direction.	71
Duty cycle regulation in two directions.	72
Duty cycle regulation.	71
Example of pressure difference regulation.	38
Example of proportional regulation.	41
Example of scaling by means of PID regulator.	40
Example of sequence regulation	36
Example of simple regulation.	34
Feedbacks.	70
Functions	1
General	1
Input Channels.	51
Limit Switch / Batching Channel.	43
Limit Switch with positive offset values, example	48
Limit Switch, example	47
Limit Switch, function	47
Measuring the SUM and difference	19
Noise limiter.	89
Output control via P-net.	65
Output controlled via timer, (pulse output).	66
PID Regulator	27
Programing of the function keys (K1-K8)	81
Registers on analog input channel (channel 1-2).	8
Registers on conductivity channel (channel 3-4).	15
Registers on Digital Output Channel	59

Sequence control.	66
Service Channel (Channel 0)	73
Simple input channels	56
Single feedback (TBM) with variable delay.	67
Specifications	87
Survey of registers in the PD 1652 module.	90
Survey of standard identifiers (Bit).	92
Survey of standard identifiers in the PD 1652 module for	91
Temperature compensated measurement	18
Temperature measurement	11
Voltage measurement, 0-500 mV.	13
Voltage Output.	84