



Flow Transmitter

PD 340

Manual

GB

Copyright by **PROCES-DATA A/S**. All rights reserved.

PROCES-DATA A/S reserves the right to make any changes without prior notice.

P-NET[®], **Soft-Wiring**[®] and **Process-Pascal**[®] are registered trademarks.



Contents

1	General information	5
1.1	Introduction.....	5
1.2	Features	5
1.3	Construction	6
1.4	Operating principles	8
1.5	Reducing the influence of varying flow profiles.....	9
1.6	Linearizing function	10
2	Function description.....	11
2.1	Flow measurement.....	11
2.1.1	Test mode	11
2.2	Volume counter	11
2.3	Automatic functions	11
2.3.1	Batch Control	11
2.3.2	Flow control.....	12
2.3.3	Limit switch.....	12
2.4	Temperature measurement.....	12
2.5	Output1.....	12
2.6	Output2.....	12
2.7	Output3.....	13
2.8	Input.....	13
2.9	P-NET Interface.....	13
2.10	PD 210 Display.....	13
3	Display	14
3.1	Local display unit, PD 210.....	14
3.2	Display registers.....	14
3.2.1	Changing register contents.....	15
3.2.2	Configuration and calibration using the PD 210	15
3.2.3	Error readout.....	15
3.2.4	Construction	15
3.2.5	Assembly drawing for PD 210	15
3.3	PD 688 Display.....	16
4	Meter selection and installation	17
4.1	Selecting the correct meter size.....	17
4.1.1	Quick Selection Guide	18
4.2	Installation and care of the transmitter.....	19
5	Electrical connections	22
5.1	Power supply	22
5.2	Output1.....	22
5.3	Digital output signals	23
5.3.1	Output2	23
5.3.2	Output3	24
5.3.3	Output3, current output.....	24

5.4	Input signal	26
5.5	Temperature signal, Pt100	26
5.6	Connecting the display unit, PD 210	26
5.7	P-NET fieldbus connections	26
6	Variable description.....	28
6.1	SoftWire Table	28
6.1.1	Process variables	31
6.1.2	Configuration and calibration parameters	34
6.2	Factory settings	39
6.3	Changing settings	40
	Changing settings from m ³ to litre measurements	41
7	3-phase output signals.....	42
7.1	3-phase counter without separate error signal (mode 3)	43
7.2	2-phase counter with separate error signal (mode 2)	43
7.3	Counter with up/down signal & separate error signal (mode 1)	44
7.4	Table showing signal mode relationships	45
8	Applications.....	46
8.1	Flow Control.....	46
8.2	Batch control using the PD 210 display.....	48
9	Fault finding.....	51
9.1	Error detection	51
9.2	Typical errors	51
9.2.1	Flow Transmitter with PD 210 display unit.....	51
9.2.2	Flow Transmitter without display unit.....	52
10	List of spare parts.....	53
11	Specifications	54
11.1	Flow measurement	54
11.2	Power Supply.....	54
11.3	Liquid	54
11.4	Measurement of temperature	55
11.5	Environment.....	55
11.6	Approvals.....	55
11.7	Dimensions and capacities.....	56
11.8	Maximum flow rates and weight	56
11.9	Material	57
11.10	Connections.....	57
12	Appendix 1	58
12.1	Memory types	58
13	Appendix 2	59



1 General information

1.1 Introduction

The PD 340 Flow Transmitter is a precision meter for the volumetric measurement of liquids that are electrically conducting.

The rugged construction of the transmitter makes it suitable for installations where solid particulates make up part of the liquid for measurement.

This manual is applicable to PD 340 Flow Transmitters that utilise the 'Version 2' electronics module.

1.2 Features

- Sanitary design
- Maintenance-free, no moving parts
- Automatic zero point correction
- High accuracy, even at very low flow rates
- Bi-directional flow
- Volumetric measurement in m³, litres, U.S. gallons etc.
- Pulse output to an electronic counter, 0-1000 pulses per second
- Pulse output to an electromechanical counter, 0-10 pulses per second
- Current output, 4-20 mA (extended version)
- Batch control function
- Limit switch function
- Flow regulator function (PI controller)
- Practically no loss of pressure
- A PD 210 display unit can be simply connected. The PD 210 unit can display accumulated volume, setpoint for batch control or PI regulator, flow rate, temperature, etc.
- Count stop/clear logic input function.
- Temperature measurement using an external temperature sensor
- Temperature compensated flow measurement
- Continuous Selftest, which can be monitored through P-NET
- P-NET Fieldbus Communication (IEC 61158 Type 4)
- EMC approved (DS/EN 61000-6-2) (DS/EN 61000-6-3)
- Vibration approved (IEC 60068-2-6 Test Fc)

1.3 Construction

The PD 340 Flow Transmitter consists of three parts: The meterhead, the electronic module, and the terminal box. ¹

The electronic module and the terminal box are the same for all sizes of transmitter.

The Meterhead consists of a stainless metering pipe with clamp connections. Two magnet coils are mounted external to the metering pipe. Two stainless electrodes are mounted inside the metering pipe.

The measuring section is designed with a square measurement chamber, which prevents changes in flow profile affecting meter accuracy (see the following chapters, *Operating principles*, and *Reducing the influence of varying flow profiles*, for details). Hence the transmitter has a wide range of flow rates within its linear accuracy. Changes from laminar to turbulent flow do not affect the linear accuracy, and changing viscosity has no effect on meter accuracy. The calibration of the meterhead is carried out during manufacture using a computer controlled calibration facility.

The Electronic Module is available in two versions, standard and extended with current output or 3-phase output. See appendix 1 for further details.

The standard version has two pulse output signals and one logic input. The transmitter can also be directly connected to a display unit.

In the extended version, one of the outputs can be configured either for pulse output or analogue current output, 4-20 mA.

The extended version can also be configured for 3-phase output. In this mode the normal separate pulse output signals are transformed to a combined 3-phased output signal.

The extended version has a built-in P-NET Fieldbus interface (IEC 61158 Type 4), which can be used for configuration, or for central data collection or control.

The Terminal Box is completely separated from the electronic module. Connections can therefore be changed without disruption to the electronics. All terminals inside the terminal box are clearly marked with both number and function.

The box is also equipped with 3 cable glands, type PG 11.



Figure 1: PD 340 C 25/C 38/C 51/C 63/C 76



Figure 2: PD 340 C 102

¹ For meter size C 102: The electronic module is an integrated part of the meterhead.

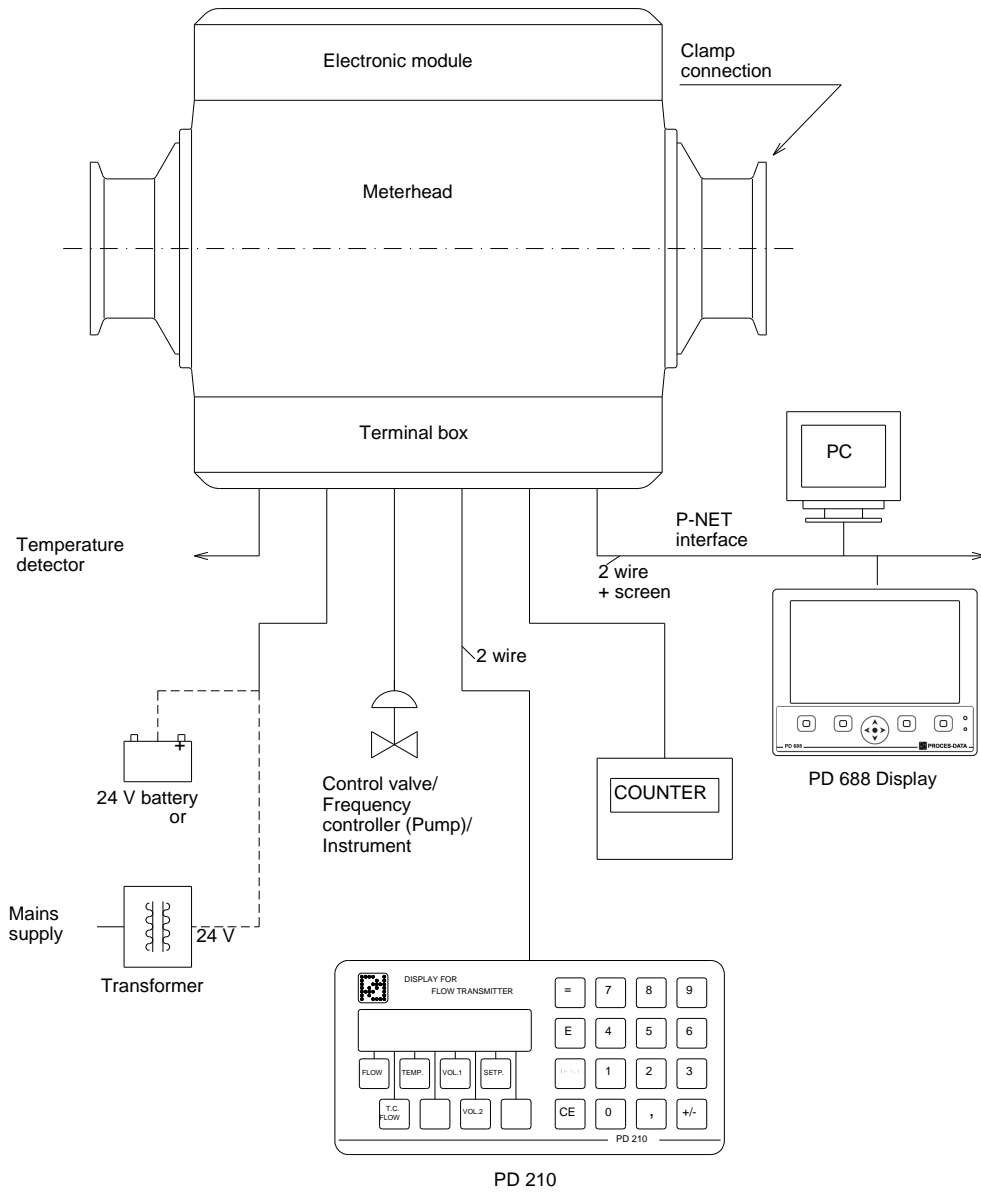

Figure 3: System diagram

1.4 Operating principles

The meterhead consists of a metering pipe and two magnetic coils. When a current is applied to the coils a magnetic field is produced at right angles to the metering pipe.

With a conductive liquid flowing through the metering pipe an electrical voltage is induced and measured by two electrodes mounted in the metering pipe. This voltage is proportional to the average velocity of flow and therefore to the volume flowing.

The PD 340 Flow Transmitter utilizes a square measurement chamber. The shape of the measurement chamber significantly reduces the influence of viscosity, type of liquid, and flow profiles (see details in the next chapter, *Reducing the influence of varying flow profiles*).

Practical tests with the PD 340 confirm that it is not necessary to recalibrate the meter when changing product, such as from water to milk. This would normally be necessary when using magnetic flowmeters that have traditional round measuring chambers.

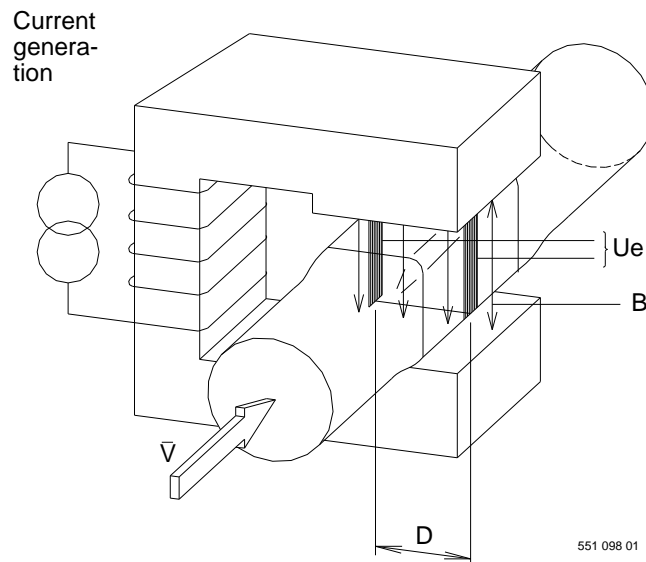

Figure 4: Operating principles

- $U_e = K \times B \times V \times D$
- U_e = voltage across electrodes
- K = system constant
- B = magnetic field
- V = average velocity
- D = distance between electrodes

The micro-processor in the transmitter controls the current generator, keeping the magnetic field constant. The voltage across the electrodes is amplified and converted to a digital value from which the micro-processor calculates the liquid flow.



1.5 Reducing the influence of varying flow profiles

When a liquid is flowing through a pipe, its velocity tends to vary from zero along the pipe wall up to its maximum through the centre of the pipe.

The velocity profile depends on the actual flow velocity together with the viscosity of the liquid.

When the flow rate is low, the velocity profile takes the shape of a parabola. This is called laminar flow. If the flow rate is gradually increased, the flow profile also changes gradually, still maintaining the laminar flow profile, until it reaches the critical velocity. At this flow rate, the flow profile will, via a transition phase, change from laminar to turbulent flow with the formation of eddies and chaotic motion, which do not contribute to the volume flow rate. The two types of flow profile are illustrated on the figure to the right. Precisely when the liquid reaches the critical velocity and changes to turbulent flow, depends on the diameter of the pipe, and on the viscosity and density of the liquid. For cream, for example, the viscosity strongly depend on the temperature and the percentage of fat, and it is therefore not possible to predict the flow profile at any given flow rates.

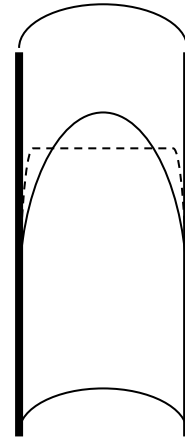

The technique used to avoid an unknown flow profile from affecting the accuracy of a measurement, consists essentially of measuring the average velocity of the liquid throughout the **full cross section of the pipe**, hence registering all the liquid passing through it.

The average measurement is achieved in a PD 340 by using a square measurement chamber, where each of the two electrodes are designed to measure across the complete cross section of flow.

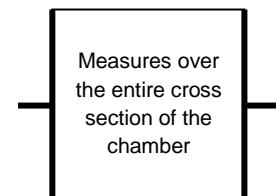

This is in contrast to flow meters having a circular cross section and point-type electrodes. Here the 'field of view' between the electrodes is limited to only involving the liquid passing directly between the electrodes. Its calibration is therefore conditional on a particular known flow profile.

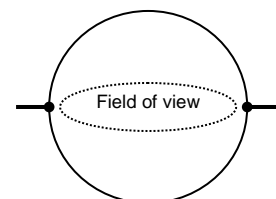

1.6 Linearizing function

Because of its construction as described in the previous chapter, the PD 340 Flow Transmitter is, by its very nature linear, even without any electronic compensation.

However, most of our customers prefer not to use anything smaller than 25 mm as a pipe diameter, even for very low flow rates. Therefore, to further improve linearity, a special compensation function has been developed and implemented within the 'Version 2' electronics module. Consequently, when this function is enabled², the PD 340 can now be used even at very low flow rates, but still offering the same well-known high accuracy measurement as normally experienced with higher flow rates.

During the flow calibration at the factory, the linearizing curve is calculated and downloaded to the electronic module. For this reason, all new PD 340 Flow Transmitters will hold the data needed by the linearizing function, when they are delivered as complete meters, i.e. meter-head and electronic module. If one of the new electronic modules needs to be mounted on a meter head with which it was not originally tested, and the linearizing function is to be used, data for the linearizing function can be downloaded to the electronic module using a PC with VIGO version 5.6 or higher installed (valid for extended version electronics only).

The graph below shows the linearizing curve for a specific flow transmitter. If this flow transmitter measures the flow rate at 20 % of full scale, this value will be compensated by $\pm 0.01\%$ of full scale.

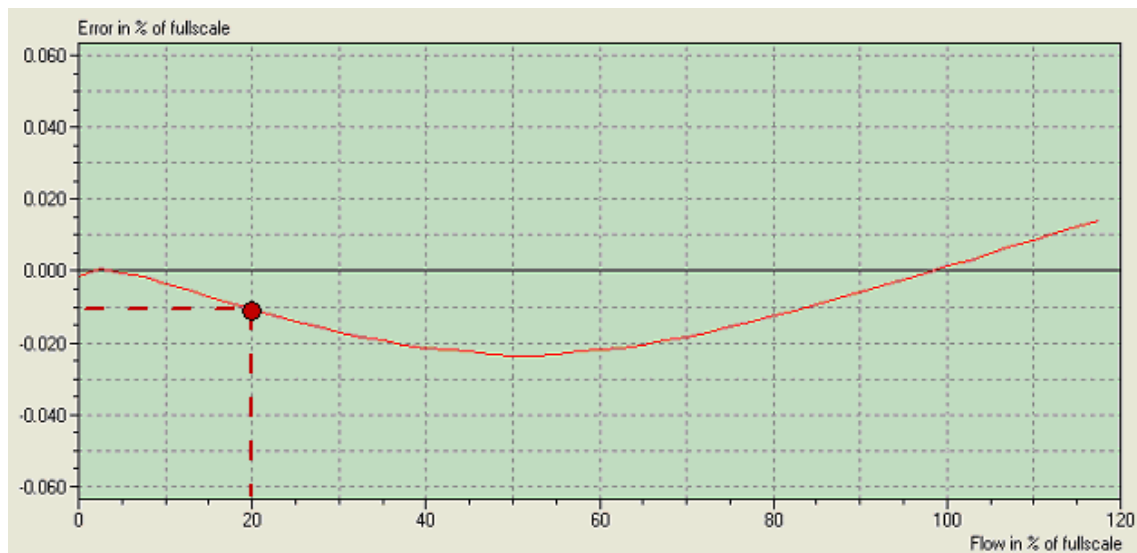

² Enable/disable: Register E7, Dig. 5.



2 Function description

The Flow Transmitter holds a number of internal functions and connections for external signals. The functions may be selected by keying in a set of configuration parameters. Calibration parameters may also be set. The data may be entered via a display/keyboard unit or via P-NET.

The Flow Transmitter may be scaled to operate in any volumetric units, Litre, m³, Gallon etc. The flow rate may be selected to be displayed as *volume unit/hour* or */minute*.

2.1 Flow measurement

The flow rate may be filtered to stabilize the readout of an unstable flow. Flow rates below 0.2 % of full scale may be ignored. This may be useful to avoid totalizing the volume during long periods with no flow (see [configuration of function selector E8](#)).

Flow is measured in both directions. Flow in the direction of the arrow on the meter head will be indicated as positive flow. Optionally, negative flow can be ignored and set to zero to prevent downward volumetric totalisation (see [configuration of function selector E8](#)).

To compensate for the expansion of the liquid, the Flow Transmitter may be configured to indicate a flow as if the liquid temperature was at 4 °C (see also [T.C. Flow](#)).

2.1.1 Test mode

The Flow Transmitter may be switched into test mode. During installation and service, the test mode may be used to simulate that liquid is flowing in the pipe system. All output signals, pulse signals as well as the current signal, will act as if the liquid flow was present. This way, all internal functions, external signals and cable connections may be checked (see [configuration of function selector E7](#)).

2.2 Volume counter

The Flow Transmitter utilizes two independent totalizers, Volume1 and Volume2, which indicate the measured volume since each were cleared. Each volume counter may be independently cleared or preset to a specific value (see [further details in the Volume1 description](#)).

2.3 Automatic functions

A number of automatic functions are selectable in the Flow Transmitter. Only one of the functions should be selected (see [configuration of function selector E7](#) about how to select each function).

2.3.1 Batch Control

The Flow Transmitter has a built-in batch control function, and can therefore easily be used to control the dosing of a specified volume. The required volume is keyed into a setpoint register. A digital input on the Flow Transmitter may be used to start the batch control. A digital output, Output2, opens the dosing valve or starts a pump. When the setpoint volume is reached, the output is switched off and the valve is closed or the pump stops. The Volume2 counter shows the dosed volume (see also the [Batch control application example](#)).

2.3.2 Flow control

In systems where it is desirable to have a constant flow, the built-in Flow Control function may be used to control a valve or pump directly. The required flow rate is keyed into a setpoint register and the internal PI controller will control the valve or pump by means of the current output signal (4-20 mA) (see the [Flow control application example](#)).

2.3.3 Limit switch

The Flow Transmitter has a built-in limit switch function. This function may be used to indicate whether a measuring value is below or above the value in the setpoint register. As an example, this may be used to indicate a high/low flow rate. The indication may appear on a digital output, Output2, as ON or OFF. See [configuration of function selector E7](#) to select this function for Output2, and details under [Setpoint](#).

2.4 Temperature measurement

The Flow Transmitter can measure temperature by connecting an external Pt100 temperature sensor. The temperature may be read in a register as °C or °F (see [configuration of register E8](#)). This would be necessary for temperature compensated flow measurement.

2.5 Output1

Output1 is a power supply output, which can be used to supply nom. 24 V DC to an external counter or relay circuit (see [further details in Chapter 5.2](#)).

2.6 Output2

Output2 can be selected for one of several functions:

- Pulse signal, 0-10 Hz. The signal may be taken to a counter, electronic or electro-mechanical, for indication of the total volume, e.g. in litres (see [Chapter 5.3.1 Output2](#)).
- Sign for Output3. The signal indicates the flow direction. The output is switched OFF, when the flow is positive. By means of an UP/DOWN counter, this signal may be used for the totalizing of the volume flowing with a sign.
- Control signal from the Batch control function.
- Control signal from the Limit function.
- Error free measurement signal. The output signal is ON if no error is present.
- The output may be controlled directly via P-NET.

(See [configuration of function selector E7](#))

Further details for connecting Output2 can be found in [Chapter 5.3.1 Output2](#).



2.7 Output3

Output3 may be used as a digital signal output **or** as an analogue 4-20 mA current output. When used as a digital signal, it may be used as a fast pulse signal (0 - 1000 Hz) for external counter circuits (see [scaling example](#) in Chapter 6), or it may be controlled directly via P-NET. Further details for connecting Output3 can be found in Chapter 5.3.2 [Output3](#).

2.8 Input

The transmitter has a logic input, Input1, which can be selected for one of several functions:

- Stop counters. The signal may be derived from an air detector, and is then used to make the transmitter stop counting, when there is air in the liquid.
- Clear Volume2 counter. The input can be used in batch control, to start the Batch function and clear the batch volume counter.
- Manual/Automatic mode for PI controller. The input can be used to set the operation mode for the PI controller.

(See [configuration of function selector E8](#)).

Further details for connecting Input1 are found in chapter 5.4 [Input signal](#).

2.9 P-NET Interface

The extended version of the Flow Transmitter utilizes a P-NET fieldbus communication interface, which enables the Flow Transmitter to be connected directly to a P-NET fieldbus network designed for process control and data-collection. P-NET is an international standard (IEC 61158 Type 4).

Through P-NET it is possible to display and change all the internal data within the Flow Transmitter (see [a complete list in the Variable Description](#)).

The PD 4000 Flowmeter-Display utilizes the P-NET interface for data exchange between the Flowmeter-Display and connected Flow Transmitters. It is possible to change data and to select various functions in each Flow Transmitter. The memory in the Flowmeter-Display is equipped with a battery backup, which will hold the measured data during a power failure.

The P-NET interface may also be used for data collection, e.g. by a PC. The PC can be equipped with a P-NET interface device, which makes it possible to directly access any variable in the Flow Transmitter and other connected P-NET modules while running a PC program.

2.10 PD 210 Display

The PD 210 is a local display unit, which is connected directly to the Flow Transmitter. From this unit it is possible to display the flow rate, volume counters, temperature, setpoint etc. Furthermore, the PD 210 display unit may be used to change setpoint values and to perform a complete configuration of the Flow Transmitter (see description in Chapter 3).

3 Display

Various options are available for displaying information from the PD 340 Flow Transmitter. The Flow Transmitter may be controlled and supervised via the P-NET interface (requires the extended version), and all data may then be accessed. Another solution is to connect a local PD 210 display unit to the Flow Transmitter. Then only the main data is accessible.

3.1 Local display unit, PD 210

The PD 210 display unit can be directly connected to the transmitter. With this unit connected, it can perform a number of different functions.

- Display of data from the transmitter, e.g. flow or volume.
- Change data in the transmitter, e.g. contents of volume register or setpoint register.
- Configuration and calibration, e.g. setting of the size of the meterhead or the function of the output signals.
- Readout and reset of an internal error code.

The display unit is connected to the Flow Transmitter with a two-wire cable, up to a length of 100 m. The display unit is supplied with power via this cable. It also carries the exchange of data between the Flow Transmitter and the display unit.

3.2 Display registers

The contents of 8 different registers in the transmitter can be displayed on the unit. A touch on one of the 8 buttons under the display selects whichever register needs to be read. The display indication is automatically updated about once per sec. Additional de-tails may be found in Chapter 6.1.1.

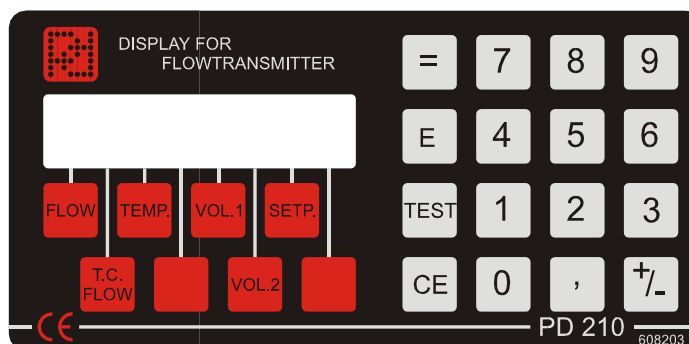

490 273 02

Reg. No.	Name	Function	SWNo
1	FLOW	Liquid flow, e.g. in m ³ /h	\$11
2	T.C. FLOW	Temperature compensated flow	\$12
3	TEMP	Temperature in °C or °F	\$13
4	"blank"	Available register	\$14
5	VOL.1	Volume, result of totalization, e.g. in m ³	\$15
6	VOL.2	Volume for comparing with Set-point, e.g. in m ³	\$16
7	SETP.	Set-point, e.g. in m ³	\$17
8	"blank"	Instant Flow	\$18



3.2.1 Changing register contents

If a change in the contents of a register is required, the register must first be displayed. Then the desired contents are entered, followed by a press on the = button. This gives a blank display for approx. 1 sec., and then the new contents are displayed in the normal way.

3.2.2 Configuration and calibration using the PD 210

The Flow Transmitter contains 8 configuration registers. See also Chapter 6.1.2 for a detailed explanation and purpose for these registers (SoftWire number 20 to 27). If it is required to display the contents of a configuration register, press the **E** button, which will turn the display blank. Then press a numeric key between **1** and **8** to choose the desired configuration register. The number of the configuration register appears in the first digit of the display, and the contents of the register in the rest of the display. Changing the contents of a register are performed by keying in the new contents, and then pressing the = button.

3.2.3 Error readout

The user is informed of an error by an "A" for ALARM appearing in the first digit of the display. By pressing the "TEST" button the display will show an error code of two digits, indicating the type of error. The test system ensures that the alarm will not be cancelled before the error code has been displayed by pressing the "TEST" button, even though the error may have disappeared. By pressing the "TEST" button once again, the display will show "00" if the Flow Transmitter is now error free. The error code on the display is **only** updated by re-pressing the "TEST" button. A complete [list of error codes](#) is given in Chapter 6.

3.2.4 Construction

The display unit consists of an LCD display, a keyboard, and electronics for exchange of data with the transmitter and control of the display and the keyboard.

The unit is built into a case of NORYL PPO, sealed to IP 65. The dimensions of the enclosure are LxHxD = 144 x 72 x 8 mm. (Standard dimensions for cabinet mounted instruments).

3.2.5 Assembly drawing for PD 210

Note: Please observe that the M3 mounting screw holes are only **4 mm.** deep.

Do **NOT** screw down beyond this length. This may damage the display unit.

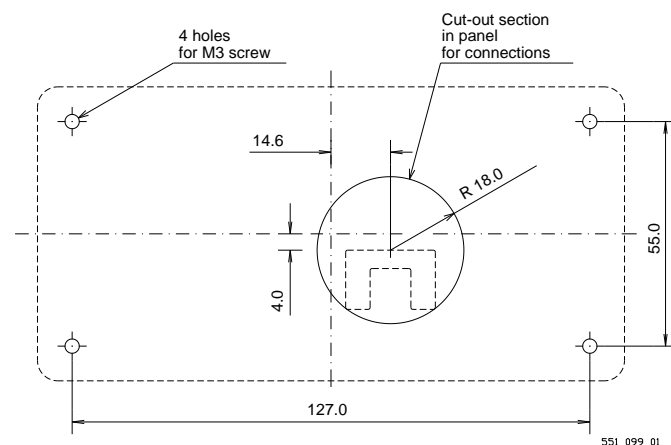

3.3 PD 688 Display

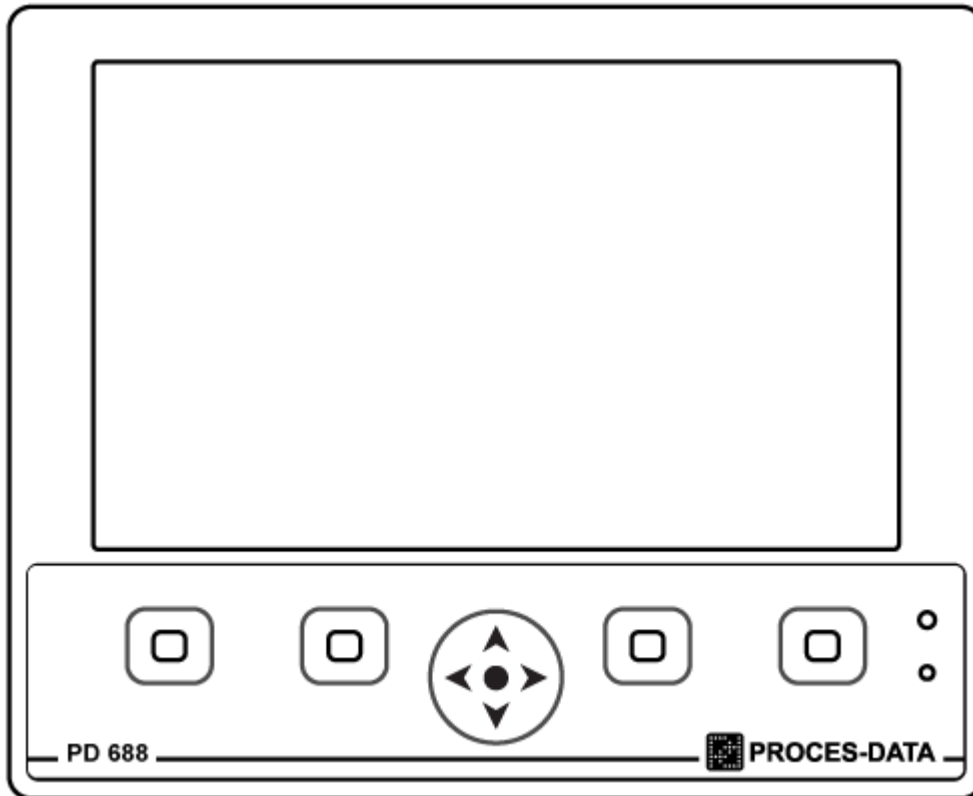

One or more controller units type PD 688 Display can be connected to PD 340 Flow transmitters in the extended version with P-NET.

Just like with the PD 210, the PD 688 Display can be used to read out actual flow, volume, configuration, and setpoint values.

PROCES-DATA offers a solution for PD688 with intuitive display screens and a wizard for configuration and backup of flow transmitters. Among other options, this solution enables the possibility of copying the configuration from one flow transmitter to another.

For inspiration of how to generate applications using the PD 688 Display and other electronics modules from the M100 series, please visit our website www.proces-data.com to achieve more information. The website contains descriptions of the programming suite VIGO6, a larger number of tutorials and user-guides, an overview with all hardware modules, prices, and other details of interest.

Additional information can be provided by sending a message to salesdepartment@proces-data.com, so please feel free to contact us.



4 Meter selection and installation

4.1 Selecting the correct meter size

The complete PD 340 Flow Transmitter family has a very large measuring range. It is normally recommended that a particular transmitter size is selected so that it will operate in the upper half of its measuring range. This is due to the fact that the influence of zero point error is relatively higher at low flow rates. This applies to any flow transmitter on the market. However, it is possible to use the PD 340 even at very low flow rates, whilst still obtaining high accuracy. Flow measurement down to 1 % of maximum flow rate for the Flow Transmitter is now possible (100:1 turndown), when the linearizing function is enabled (refer to [Linearizing function](#) in Chapter 1).

Practical examples from different installations indicate that actual expected operational flow rates do vary. It is therefore recommended that the calculated maximum flow rate should not exceed **90 %** of the specified maximum flow rate for the selected Flow Transmitter. Exceptions may be made if the flow rate is well known and very stable.

As a rule, a Flow Transmitter with a pipe dimension equal to the rest of the piping system should be selected.

The size of the meterhead should be selected according to the maximum flow rate. This maximum flow rate must be the absolute maximum flow rate during operation, cleaning, startup etc. The smallest possible transmitter is then chosen for that maximum flow rate. This will ensure optimum measurement accuracy. If the metering section is smaller than the pipework in the installation, the connecting pieces should be tapered.

A Flow Transmitter should not be installed in a pipe construction where the pipes are smaller than the pipes in the connections.

If two products are mixed before measuring, the mixed product must be a homogenous liquid before entering the Flow Transmitter to ensure maximum accuracy.

The Flow Transmitter is available in 5 different sizes as shown in the table below:

Max. flow rate:

C 25	C 38	C 51	C 63	C 76	C 102
8 m ³ /h	20 m ³ /h	40 m ³ /h	80 m ³ /h	120 m ³ /h	200 m ³ /h

Note: The max. flow rate for the Flow Transmitter must NEVER be exceeded, otherwise the meterhead may be damaged.

4.1.1 Quick Selection Guide

Use the following diagram as a guideline for selection of the meter size, and then take the following precautions:

- Never exceed the maximum flow rate of the flow transmitter.
- If optimum measurement accuracy is of primary concern, the smallest possible transmitter should be chosen, while still observing that the maximum flow rate must not, under any circumstances, be exceeded.
- To further improve accuracy, especially at very low flow rates, the [Linearizing function](#) should be enabled.

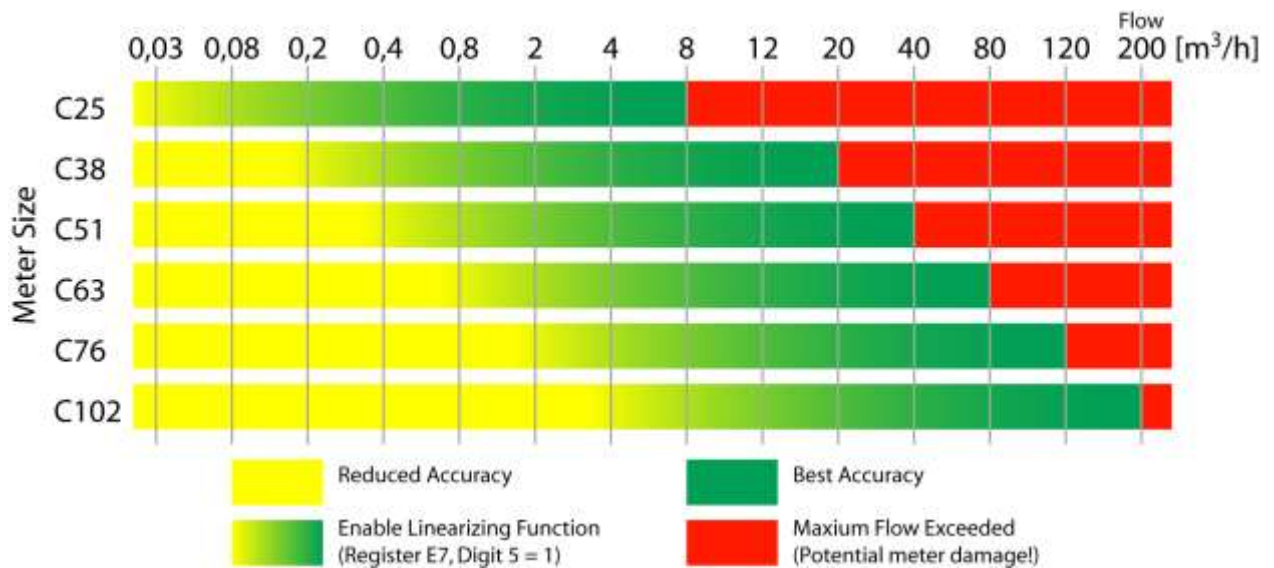



4.2 Installation and care of the transmitter

The transmitter should be installed within the pipe work system such that the metering pipe is always filled with liquid, because the transmitter can register some flow, even when the meter is empty.

As the transmitter will measure any air in the liquid as a part of the total volume, the volume of the air must be reduced to an absolute minimum. To help achieve this, the transmitter should be located in the pipe work system at the point of maximum pressure. Here the volume of the air will be at a minimum and thus the influence of air on the measurement will also be at a minimum. It is therefore recommended that control valves, or other restrictions that might create a pressure drop, are mounted after the Flow Transmitter. Even when there is no air in the liquid it is important to ensure that the pressure is sufficiently high, otherwise cavitation may occur in the transmitter. Not only will this influence the accuracy, but it is also destructive to the Teflon lining.

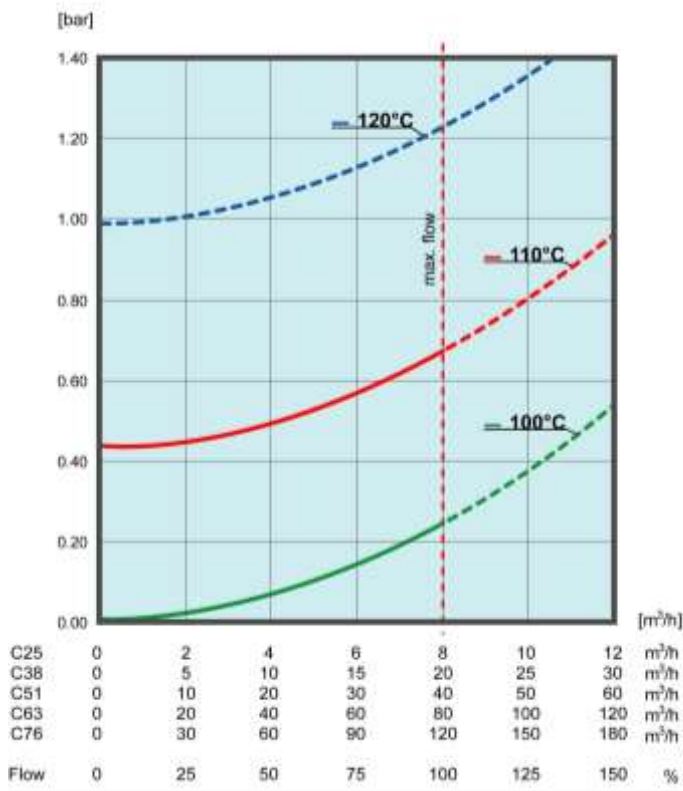
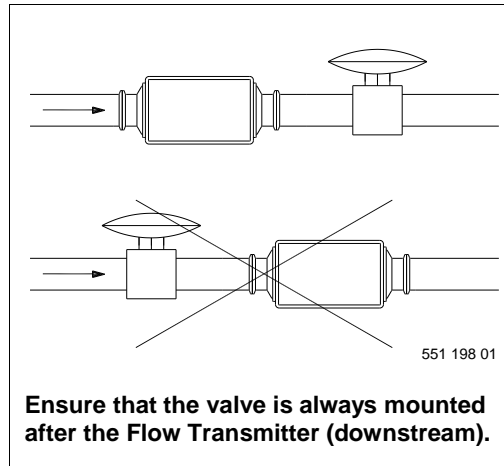

The graphs to the left show the required minimum gauge pressure (measured in the pipeline after the Flow Transmitter) as a function of flow at different operational temperatures. Always ensure that the gauge pressure is well above the curve defined by the relevant operational temperature. Please observe that the dotted parts of curves fall outside the allowable operational specifications and are only shown as extrapolations from permitted values. Using the transmitter under these conditions may cause damage, which will not be covered under the product guarantee.

If heavy vibrations can occur in the pipe work caused perhaps by resonance from pumps, or a pulsating pressure in connection with, for example, a homogenizer or a positive displacement pump, then vibration damping is required, or the transmitter should be mounted somewhere else where there is less variation in pressure.

If the liquid contains air, an air eliminator should be mounted before the flow Transmitter.

The transmitter can be mounted both horizontally, vertically and tilted. No air must be trapped in the meter head.

Note: In hygienic applications the flow meter must be installed in an angle of minimum 20° to horizontal. This will ensure a correct self-draining property.

In non-food applications, with no requirement for draining, the flow meter may be mounted horizontally.

Please refer to the following table:

Mounting in a vertical pipeline:

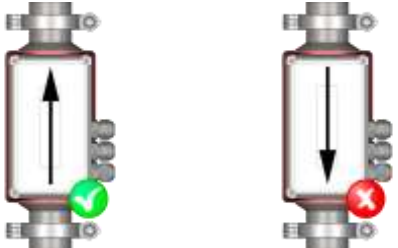
 <p data-bbox="228 1227 400 1249">Recommended</p> <p data-bbox="480 1227 695 1249">Not recommended</p>	<p>When mounted in a vertical pipeline, upward flow is recommended. The reason for this is that any air within the liquid will easily follow the liquid in its upward direction, which would not be the case with downward liquid flow.</p>
--	---

Mounting in a horizontal pipeline:

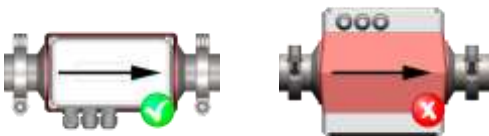
 <p data-bbox="228 1603 400 1693">Recommended for non-food applications</p> <p data-bbox="480 1603 695 1626">Not recommended</p>	<p>When mounted in a horizontal pipeline, orientation as shown in the figure to the left is recommended. Mounting the meter as shown in the figure to the right would mean that one of the electrodes would be positioned at the top of the meter tube, and any air bubbles might cause the electrode to lose contact with the liquid.</p>
---	--

**Mounting in a tilted, upward pipeline:**

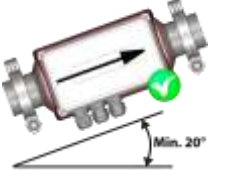
 <p>Recommended for hygienic and non-food applications</p>	<p>Mounting in an angle of minimum 20° to horizontal as shown in the figure to the left will ensure the correct self-draining property in hygienic applications, for example EHEDG and 3-A.</p>
--	---

The positive flow direction is indicated by an arrow on the meterhead.

To create the best conditions for precise metering, and to maximise the lifetime of the transmitter, a straight pipe run of at least three times the pipe work diameter should be mounted upstream and downstream of the transmitter. This is especially important when running at high temperature and high flow rate, since the risk of cavitation is increased with turbulent flow.

When selecting the location of the transmitter it must be ensured that the ambient temperature is within the specified limits. Finally, the transmitter should be installed such that the electronic module and the terminal box can be fitted and dismantled in situ.

Note: The clamp connections **must** be loosened completely before the transmitter is rotated. Otherwise the meterhead may be fatally damaged.

Precautions must be taken to ensure that neither the electronic module, nor the meterhead, nor the terminal box is exposed to moisture, when the transmitter is dismantled. To prevent moisture, the cables must be mounted correctly in the glands. The electronic module and the terminal box must be carefully mounted with all screws tightened.

The Flow Transmitter supply should always be connected, as heat developed in the electronic module prevents any condensation, which could damage the transmitter. The transmitter should therefore be powered up as soon as possible after mounting.

5 Electrical connections

The figure below shows the terminal board with all the possible electrical connections for the Flow Transmitter. The *program enable* switch, SW1 located in the upper left corner, must be in the ON position when configuring and calibrating the Flow Transmitter. After configuration and calibration, the switch must be set in the OFF position.

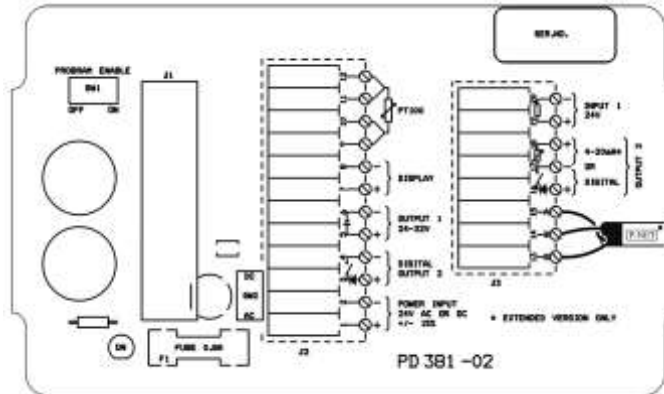

Figure 5: Electrical connections in Terminal Board

5.1 Power supply

The power supply for the Flow Transmitter can be either 24 V DC or 24 V AC. Terminal boards marked 'PD 381-02' will have a 2-position switch, SW2. If SW2 is set to 'AC' (factory setting), the supply voltage can be either AC or DC. If SW2 is set to 'DC', it must be supplied with DC. The 'DC' setting can be used on mobile applications to comply with OIML requirements.

If the conductivity for the liquid is below the specified 5 $\mu\text{s}/\text{cm}$, it might still be possible to measure the flow. To do this, the Flow Transmitter must be connected to a separate DC power supply with the -24 V DC terminal connected to the piping system.

This will increase the sensitivity, and flow measurement may still be possible.

5.2 Output1

Output1 on the terminal board is a voltage supply, which can be used to supply an external counter circuit, relays or current devices (4-20 mA).

The voltage at the output can vary from 20 to 40 V DC, depending on the power supply voltage (Supply voltage - 2 V as minimum).

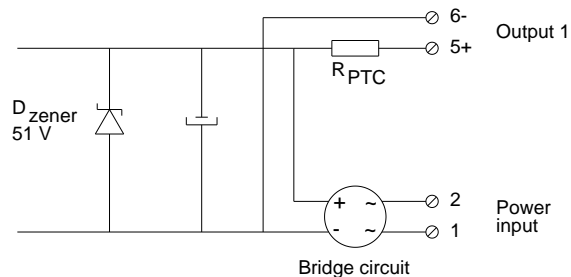

551 104 01

Figure 6: Power supply output electrical

The voltage supply is connected directly to a bridge circuit, which rectifies the power supplied to the transmitter. The output is protected with a zener diode and a current-limiting resistor in the same way as the pulse outputs. Furthermore, the output is isolated from the internal electronics by a transformer. The output is **not** isolated from the power source supplying the transmitter.



5.3 Digital output signals

The Flow Transmitter has two digital output signals, Output2 and Output3. Voltage supplies are required for output signals.

The outputs are isolated from other parts of the electronics by optocouplers. Furthermore, the outputs are protected against overload by a zener diode and a current-limiting resistance, R_{PTC} . R_{PTC} is about 25 Ohms at normal load (max. 100 mA). At overload, the R_{PTC} will rise rapidly thus limiting the current to about 16 mA.

If an output has been overloaded, the current must be completely switched off for some seconds, by switching off the power supply to the Flow Transmitter, before the output can be normally loaded again.

A voltage drop of up to 1.0 V may occur when the output is switched ON. This should be noted when connecting to low voltage external equipment.

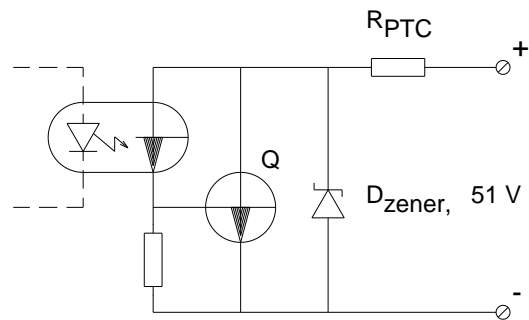

551 105 01

In case of wrong polarization of the connection, the signal acts as a constant ON signal.

5.3.1 Output2

The pulse output signal from Output2 has a pulse width of 40 ms. The frequency is continuously variable from 0-10 Hz.

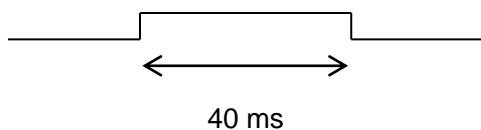

Pulse signal Output2

Example of electrical connection of electro-mechanical counters.

Counter specification:

- Supply voltage: 20-40 V DC
- Power consumption: Max. 2.5 W
- Counting frequency: Min. 10 Hz
- ON-time: Typ. 40 ms
- OFF-time: Min. 60 ms

FLOW TRANSMITTER

COUNTER

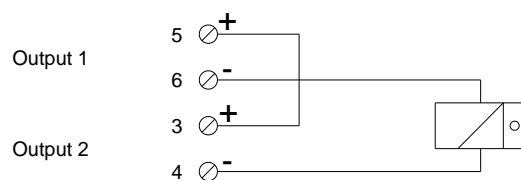

551 106 01

5.3.2 Output3

The standard version of the Flow Transmitter can generate a pulse output signal at Output3. A voltage supply is required for this pulse output signal.

The extended version of the Flow Transmitter can generate two different output signals at Output3, a pulse output signal **or** an analogue current output signal. Voltage supplies are required for both types of signals.

The pulse output signal from Output3 is symmetrical (50 - 50 % duty cycle), and the frequency is continuously variable from 0-1000 Hz.

Electronic counters and PLCs are normally connected to the pulse output, Output3.

The pulse output in the transmitter consists of a voltage free electronic switch contact. Therefore, it is necessary to equip the count pulse input on the counter/PLC with a pull-up or pull-down resistance, in case the counter/PLC has no such built-in internal resistance.

The first diagram illustrates the wiring for a PLC with NPN input, i.e. negative logic.

The second diagram illustrates the wiring for a PLC with PNP input, i.e. positive logic.

The pull-up or pull-down resistance R1 should be chosen so that the current I is approx. 5 mA when the contact in the Flow Transmitter is switched on. At 24 VDC supply voltage, a 4.7 kΩ resistor is adequate.

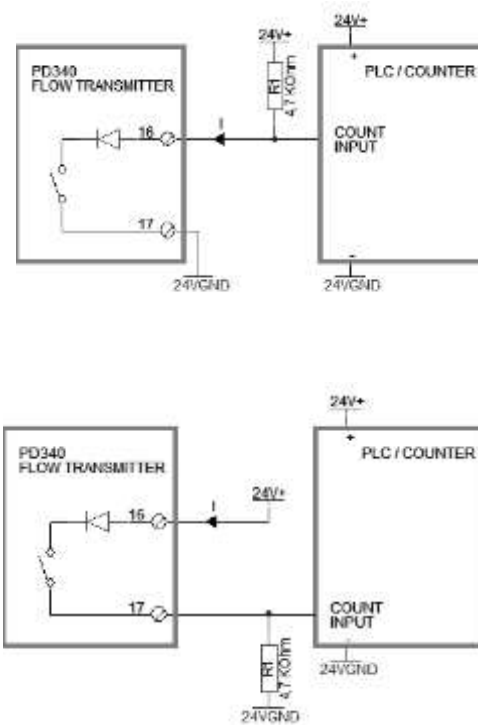

5.3.3 Output3, current output

The current output signal is in the range from 4 - 20 mA. The current output may be taken to a regulator for controlling the liquid flow.



The current output from Output3 works as a variable resistance. It therefore requires an external supply voltage, which can provide min. 12 V at terminals 17 and 18 in the Flow Transmitter plus the voltage drop across the load and cable. The necessary supply voltage must be calculated for max. current, 20 mA.

The current output is isolated from other parts of the electronics and protected against overload in the same way as the pulse outputs. However, the current-limiting resistance R_{PTC} is designed so that overload protection comes into force at about 35 mA.

Current signal:

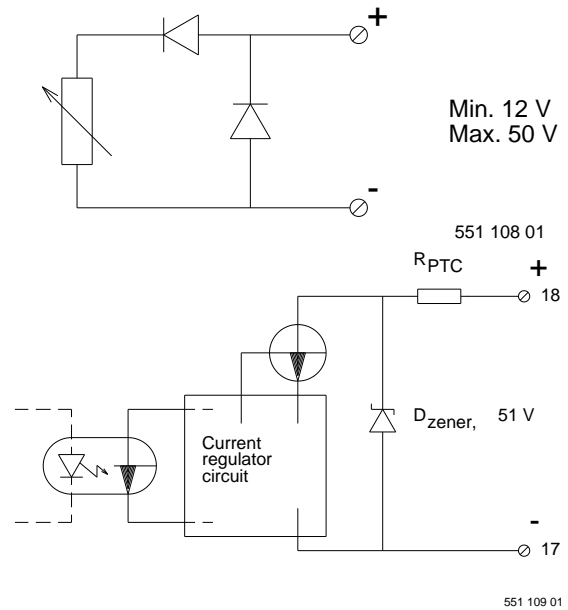

Supplied by internal voltage supply (Output1)

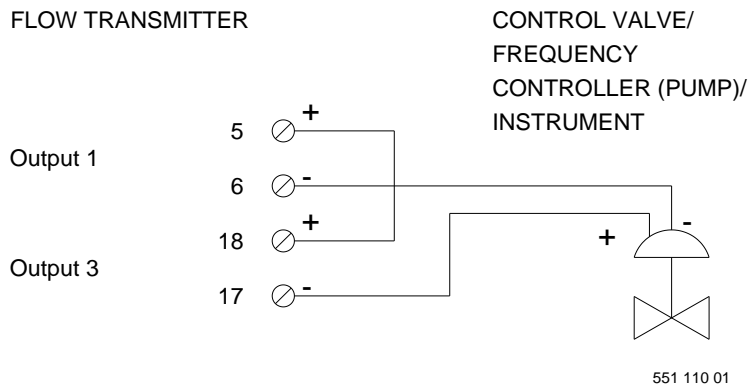

Supplied by an external power supply

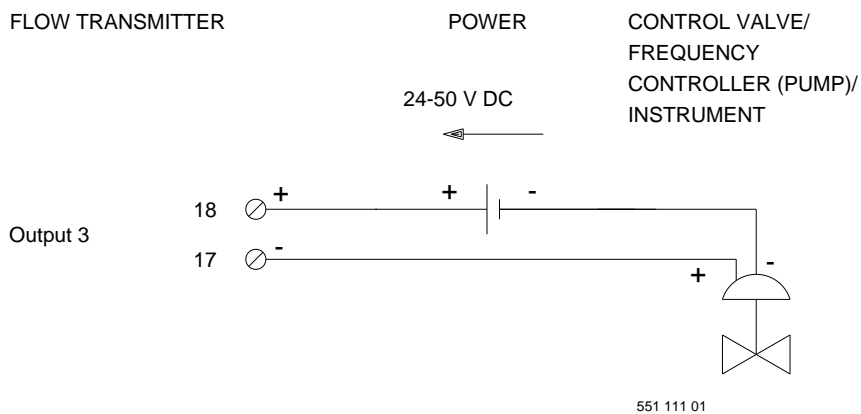

5.4 Input signal

The input signal is galvanically isolated. To activate the input, a voltage of minimum 18 V must be connected to the terminals with the right polarization. This voltage may be supplied from either the internal voltage supply or an external power supply.

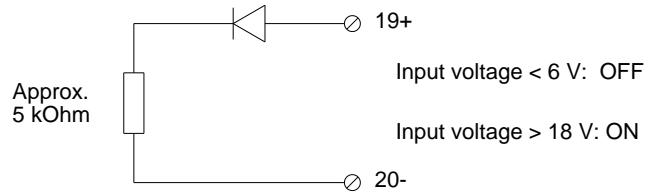

551 112 02

5.5 Temperature signal, Pt100

A standard Pt100 temperature sensor may be connected to the Flow Transmitter. The temperature sensor must be connected with a 4-wire cable all the way from the sensor to the terminal box. This must be done to avoid errors introduced by the cable length, junctions and connections. The cable that connects the Pt100 temperature sensor to the Flow Transmitter must not exceed 25 m.

Note 1: The sensor wires **must not** be connected to the sensor housing (grounded).

Note 2: If a temperature sensor is not used, the terminals 9-10-11-12 **must** be connected together in order to avoid errors in the flow measurement. Do not connect any other kind of resistors except Pt100 sensors, as a resistance out of range could influence the results of the measurements without your knowledge. Due to this fact, it must also be ensured that the 4-wire cable connections between the sensor and the terminals are steady and reliable.

5.6 Connecting the display unit, PD 210

The display unit is connected to the Flow Transmitter with a two wire twisted cable, up to a length of 100 m. The display unit is supplied with power via this cable. It also carries the exchange of data between the Flow Transmitter and the display unit.

The communication speed between the Flow Transmitter and the PD 210 display unit is 300 bit/sec, resulting in a updated data readout of approx. every second.

To improve the electrical noise immunity with long length cables, a shielded cable is recommended. In this case the shield should be connected to terminal 8 at the terminal box and **not** connected at the display unit.

5.7 P-NET fieldbus connections

P-NET is standardised internationally (IEC 61158 Type 4). Up to 125 units can be connected to the fieldbus, where a device may be a PD 340 Flow Transmitter, a Flowmeter Display or another P-NET interface module. The P-NET interface is galvanically isolated. The fieldbus cable



is a twisted pair cable with shield, and the shield is used as a potential equalizer between the driver/receiver circuits in the nodes connected to the fieldbus.

A P-NET device is connected to the fieldbus by means of 3 terminal connections, the A terminal, the B terminal and the S terminal.

The connection from one device to the next unit is performed by connecting A to A, B to B and S to S. The S terminal must **not** be connected to ground. If the length of the cable is more than 100 m, the bus cable will have to be connected from field device to field device, forming a physical ring.

For further information regarding P-NET installation, wiring, and cable types, please refer to the P-NET Installation Guide on www.proces-data.com/p-net-introduction/

Electrical specification for P-NET:

Topologies:	Physical ring without termination, or bus topology.
Medium:	Shielded twisted pair cable with minimum 0.22 mm ² area conductors and characteristic impedance of 100-120 Ω. For example TWINAX IBM part No. 7362211 with 105 ±5 Ω, 51 pF/m.
Cable length:	Max. 1200 m (EIA RS 485).

6 Variable description

PD 340 Flow Transmitter holds a number of variables and functions, which all may be accessed via P-NET and some via the PD 210 display unit.

6.1 SoftWire Table

The variables in the PD 340 Flow Transmitter are located at logical addresses called SoftWire numbers. These variables are used to define the size of the meterhead setpoint for the PI regulator, function of output signals etc. An overview of these variables and related SoftWire numbers are shown in the following SoftWire table. The memory type is explained in Appendix 1. The electronic version of this manual also offers the option of using the links to enter another document that describes each type of memory.

At delivery, the transmitter is programmed for the functions specified on the order.

SWNo (hex)	Identifier	Memory type	Read out	Type	SI Unit
0	SerialNo	Special function	Hex	LongInteger	
1	DeviceType	PROM ReadOnly	Decimal	Integer	
2	PrgVers	PROM ReadOnly	Decimal	Integer	
3	Error3	RAM ReadWrite	Hex	Byte	
4	Output2	RAM ReadWrite	Hex	Byte	
5	Output3	RAM ReadWrite	Hex	Byte	
6	Input1	RAM ReadOnly	Hex	Byte	
7	BatchStart	RAM ReadWrite	Hex	Byte	
..					
11	Flow	RAM RPW	Decimal	Real	*1
12	TcFlow	PROM ReadOnly	Decimal	Real	*1
13	Temperature	PROM ReadOnly	Decimal	Real	*2
14	Available	RAM Init EEPROM	Decimal	Real	
15	Volume1	RAM ReadWrite	Decimal	Real	*3
16	Volume2	RAM ReadWrite	Decimal	Real	*3
17	SetPoint	RAM Init EEPROM	Decimal	Real	*3
18	InstantFlow	PROM ReadOnly	Decimal	Real	*3
..					
20	MeterSize	EEPROM RPW	Decimal	Real	*3
21	Ti	RAM Init EEPROM	Decimal	Real	s
22	PICode	RAM Init EEPROM	Hex	LongInteger	
23	MeterNumber	PROM ReadOnly	Hex	LongInteger	
24	Scale	EEPROM RPW	Decimal	Real	*4
25	Code1	EEPROM RPW	Hex	LongInteger	
26	Code2	EEPROM RPW	Hex	LongInteger	
27	Code3	EEPROM RPW	Hex	LongInteger	

NOTES:

1. Flow may be read out as 'unit/min' or 'unit/hour'
2. The unit for Temperature may be °C or °F



3. The unit for Flow depends on the calibration factor inserted in MeterSize.
4. If Output3 is configured as a regulator, the SI unit for Scale must be the same as for Flow.

PD 210 display: this register is not accessible from PD 210 **P-NET SWNo 0: SerialNo**
This register contains a production serial number, which is set by **PROCES-DATA** and cannot be changed. This serial number is printed on the electronic module.

The serial number is used for service purposes and as a 'key' to set the P-NET node address for the Flow Transmitter. When setting the P-NET node address, the least significant byte in the serial number holds the P-NET node address and the serial number is contained in the 3 most significant bytes (6 digits).

Setting the P-NET node address using the serial number to identify a particular device, is achieved by writing the compound number into the serial number register (possibly using a broadcast address = \$7E (hex)).

The last data byte must hold the chosen P-NET node address for the Flow Transmitter with that serial number. The first 3 bytes **must** contain the same serial number as that already held in the 3 most significant bytes of the SerialNo register. If a device detects that the two serial number bytes are not identical, the P-NET node address will not be changed from that already set.

Obtaining a readout of the P-NET node address using the serial number is performed by reading the serial number and then masking to reveal only the least significant byte (possibly using the broadcast address = \$7F (hex)).

Note: When reading the P-NET number / serial number using the broadcast node address = \$7F, all modules connected to this P-NET segment will answer. Therefore, only the module needing the address change should be connected to P-NET. When setting the P-NET node address via the serial number with the broadcast node address = \$7E, all modules on the P-NET will receive the message, but none will give a reply (as would be the case in a normal transmission). Therefore, a transmission error will be generated.

PD 210 display: this register is not accessible from PD 210 **P-NET SWNo. 1: DeviceType**
This register holds information about the type of device, and may only be read out via P-NET. The device type for the Flow Transmitter is **340**.

PD 210 display: this register is not accessible from PD 210 **P-NET SWNo. 2: PrgVers**
This register holds information about the program version, and may only be read out via P-NET.

PD 210 display key: TEST **P-NET SWNo. 3: Error3**
The flow transmitter is equipped with a comprehensive test system, which is able to disclose faults, arising from improper use of the transmitter, or faults arising from the transmitter dur-

ing use. When the test system registers a fault, an error code is generated and saved in this register. If more than one error occurs at the same time, only the highest error code will be saved. The error code will be saved until it has been read out. By reading out the error code twice, one can see if the error has disappeared. The error codes F0 through F4 can only be read out via P-NET. By writing \$FF (hex) in Error3, the Flow Transmitter will perform a Reset, and error code \$F2 will be generated.

The PD 210 display unit will show the text "P.FAIL" after resetting the transmitter whatever caused the reset.

ERROR CODE	FAULT TYPE
F4	RESET due to internal error
F3	RESET due to internal error
F2	RESET due to \$FF in error code via P-NET
F1	RESET due to internal error
F0	RESET due to power cut
83	Error in program storage (PROM)
82	Error in program execution - watchdog
81	Error in data storage (RAM)
80	Error in program execution
76	Error in EEPROM-storage
75	Error in RAM-storage or EEPROM-storage
64	Improper connection of temperature sensor
63	Improper connection of temperature sensor
62	Temperature sensor disconnected
54	Magnetic coil in meter head disconnected (may also occur from empty metering pipe)
52	Magnetic coil in meter head short-circuited (may also occur from empty metering pipe)
44	Shunt in meter head defective
43	Shunt in meter head defective
42	Shunt in meter head defective
24	Temperature >> max
23	Temperature > 130 °C / 266 °F
08	Overrun, volume counter 2
07	Overrun, volume counter 1
05	Input active
04	Flow >> max / metering pipe empty
03	Flow > max
02	Overflow, Output2
01	Overflow, Output3
00	No error
A - - - - -	Power supply too low or display powered via a poor connection



PD 210 display: this register is not accessible from PD 210 **P-NET SWNo. 4: Output2**

This register may be used to control Output2, and holds information about the current state of the output.

If an automatic function is selected for Output2, only this function can control the state of Output2.

Output2 = 00 => Output OFF
Output2 = 01 => Output ON

PD 210 display: this register is not accessible from PD 210 **P-NET SWNo. 5: Output3**

This register may be used to control Output3, and holds information about the current state of the output when it is used as a simple digital output.

If an automatic function is selected for Output3, only this function can control the state of Output3. In this case, the state of Output3 will change rapidly, depending on the output pulse frequency or current output value and there is not much to be gained by reading the state.

Output3 = 00 => Output OFF
Output3 = 01 => Output ON

PD 210 display: this register is not accessible from PD 210 **P-NET SWNo. 6: Input1**

This register holds information about the current state of Input1. Input1 cannot be controlled internally.

Input1 OFF => Input1 = 00
Input1 ON => Input1 = 01

PD 210 display: this register is not accessible from PD 210 **P-NET SWNo. 7: BatchStart**

When the Output2 function is set to batch control, batching is started either by activating Input1 or by inserting 01 in this register. The register is reset immediately, the volume counter Volume2 is cleared, Output2 will turn ON and dosing starts.

6.1.1 **Process variables**

PD 210 display key: FLOW

P-NET SWNo. 11: Flow

This register can show the current Flow rate for the liquid in the Flow Transmitter. The Flow rate is an averaged value, where the time constant for the digital filter and the flow rate in unit/min. or unit/hour can be selected in the E8 register. The time constant for the filter can be chosen to be one of four values in the interval between approx. 0.15 sec. and approx. 10 sec. Reverse flow (relative to the arrow on the meter head) can be set to 0, as well as Flow rates smaller than 0.2% of max. flow can be set to 0 (selected in E8).

PD 210 display key: T.C.FLOW**P-NET SWNo. 12: TCFlow**

In addition to the normal flow measurement, the Flow Transmitter also measures a temperature, which may then be used to calculate a temperature compensated flow.

The calculation of the temperature compensated flow is performed to compensate for the expansion of the liquid as a function of the liquid temperature.

The Flow Transmitter automatically calculates the temperature compensated flow by multiplying the flow rate by a temperature dependent correction factor, K.

The temperature compensated flow, TCFlow, may be read directly in this register.

The relationship between temperature and K is stored in the Flow Transmitter and is shown below.

Implementing an automatic calculation of TCFlow in the entire temperature range requires a Pt100 temperature sensor to be connected to the terminals 9, 10, 11 and 12.

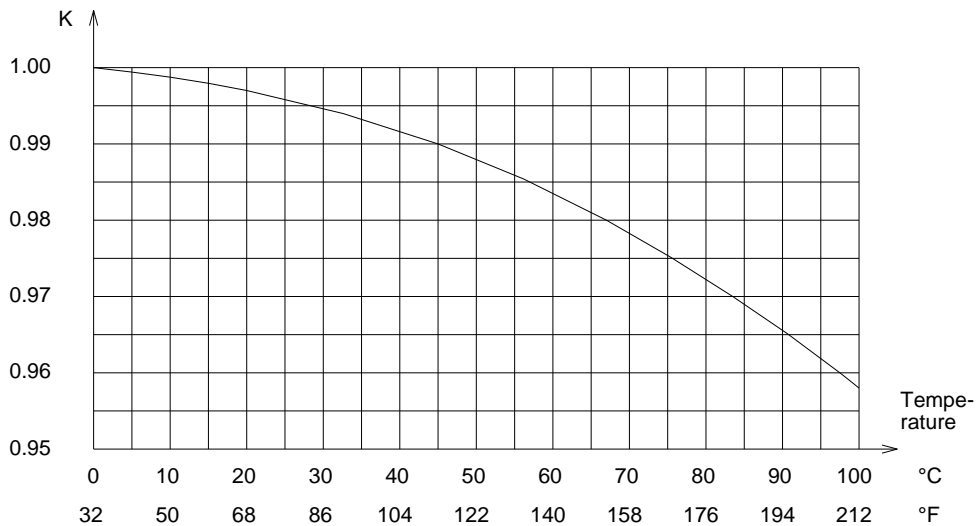

551 113 01

Temperature compensation may be implemented for liquids at fixed temperature without using a Pt100 temperature sensor. This is shown in the following example:

The liquid is at a fixed temperature of 75 °C during production. No Pt100 sensor is connected, but temperature compensated flow is required for the volume counters.

The value for the correction factor K is read from the above diagram, 0.975. This value should now be multiplied by the value from SWNo. 20 (PD 210: **E1**), Metersize and then stored back in Metersize. The E7 register's digit 4 should be set to **1** in order to select Flow as data for volume counters.

Note: Using this kind of temperature compensation will only give the correct result when the liquid is at the fixed temperature.

**PD 210 display key: TEMP.****P-NET SWNo. 13: Temperature**

This register can show the temperature, calculated using the Pt100 sensor connected to the Flow Transmitter. If the four terminals for the temperature sensor are short-circuited, the calculated temperature will be approx. ± 245 °C, equal to ± 409 °F. The calculation unit for temperature is selected in the E8 register.

PD 210 display key: 1st "blank"**P-NET SWNo. 14: Available**

The Available register has several functions depending on the selected options for Output3 and Batch control / Limit switch:

- If the **Output3 function** is set to **current output with PI-regulator**, the Available register contains the output value from the regulator. The output value will be in the range 0 to 100%, corresponding to 4-20 mA or 20-4 mA, depending on the selection in the PI-Code register. If the PI-regulator is in Manual operation, then a value may be written into the Available register, giving the output value for the current output.
- The Available register may be used as **Data input** for **Batch control / Limit switch**.
- If none of the above options are selected, this register may be used as a free register for storing Real values.

PD 210 display key: VOL.1**P-NET SWNo. 15: Volume1**

This register can show one of the two internal volume counters in the transmitter. The counter increments when the flow is positive and decrements when the flow is negative.

The read-out resolution (number of digits after the decimal point) on the PD 210 display unit for the counter is chosen in the E6 register. This read-out resolution also determines the overflow value for the counter. The counter value uses a total of 6 significant digits including the digits after the decimal point.

When the counter has reached its maximum, error code 07 is generated, and the counter starts from 0 again. The maximum value for the counter is reached when all 6 significant digits show the value 9. The corresponding volume depends on the counter resolution. If the resolution is 3 digits after the decimal point and the meter size is inserted in m³, maximum will be 999.999 m³ – even if there is no PD 210 display unit connected to the transmitter.

PD 210 display key: VOL.2**P-NET SWNo. 16: Volume2**

The Volume2 counter is similar to the Volume1 counter, though error code 08 is generated at overflow. Furthermore it is possible to clear Volume2 by means of Input1 or Batchstart.

PD 210 display key: SETP.**P-NET SWNo. 17: Setpoint**

The Setpoint register has several functions depending on the selected options for the PI-regulator and Batch control / Limit switch:

- If the Output3 function is set as a regulator, the setpoint for the regulator is inserted here. The setpoint is inserted in the same unit as the amount to be regulated - e.g. m³/h.

- If the Output2 function is set for Batch control, the setpoint for the batching is inserted here. After batch start (via Input1 or BatchStart) Output2 will be ON until the volume counter has reached the Setpoint. This function works for positive values **only**.
- If the Output2 function is set as Limit switch, the limit is inserted in this register. If data for the limit switch is below the limit, Output2 will be OFF. If data is above the limit, Output2 will be ON.

As Setpoint may be used for Output2 as well as Output3, it is **not** possible to use the regulator function for Output3 **and** either the batch control or limit switch function for Output2 at the same time.

PD 210 display key: 2nd "blank"

P-NET SWNo. 18: InstantFlow

This register shows the flow directly as it is measured in the transmitter.

- The read out is not conditioned through the digital filter
- Reverse flow is shown
- Flowrates lower than 0.2% of maximum flow are shown
- The actual flow is shown - even if the transmitter is in TEST-mode

6.1.2 Configuration and calibration parameters

E1, Size of Meter

P-NET SWNo. 20: MeterSize

The meter size, as shown on the meter head, is normally inserted in this register. On the meter head, the meter size is stated in m³/h. If another volumetric unit is required to be used for measurement results, the value of MeterSize should first be converted to the equivalent in the new unit and then stored as the calibration factor. This value must always be stated in **volume units per hour** - even if the required Flow read out is to be volume per minute.

Example: On the meter-head the meter size is shown as 80 m³/h. The required volume unit is litres, so insert $80 \times 1000 = 80000$ in MeterSize.

E2, Integration time Ti

P-NET SWNo. 21: Ti

Ti is the integration time constant for the PI-regulator, which is the time it takes for the I-component of the regulator to give the same change in the output signal as that made by the P-component, following a permanent change of the input signal. If Ti is equal to 0, the I-component of the regulator is disabled and set to zero.

See also the application example [Flow control](#).

Please consult the specialist literature on the subject of process control for further information on how to set the regulator parameters for particular purposes.

E3, PI-regulator function

P-NET SWNo. 22: PCode

The content of this register defines the function of the PI-regulator and the current output (where **in** determines the calculation of the input signal and **out** determines control direction for the current output). The register also holds an operation mode selector (Manual/Auto).



The data type for PCode is a LongInteger, which may be considered as 8 digits in hexadecimal readout. The first 6 digits represent and select an optional function. Digits 7 and 8 are not used and should be set to 0. The information must be interpreted as shown below (only digits 1 to 6 are applicable to the PD 210 display unit):

Value	Dig. 1	Dig. 2	Dig. 3	Dig. 4	Dig. 5	Dig. 6	Dig. 7	Dig. 8
					Regulator Function	Regulator operation mode		
0	0	0	0	0	in=setpoint-data out 0-100%: 4-20mA	Auto	0	0
1					in=data-setpoint out 0-100%: 4-20mA	Manual		
2					in=setpoint-data out 0-100%: 20-4mA	Input ON => manual operation		
3					in=data-setpoint out 0-100%: 20-4mA			

E4, Meter number

P-NET SWNo. 23: MeterNumber

The meter head serial number may be retrieved from this register. This number is set by PROCES-DATA and is used for service purposes only. The serial number is printed on the side of the Flow Transmitter meter head.

Note: If the electronics module was delivered as a stand-alone module, E4 will hold the 6 least significant digits of the electronics module's own serial number, which is printed on the module. For example, if the serial number is 20005176, E4 will hold 005176.

E5, Output3 scaling

P-NET SWNo. 24: Scale

This register is used for the scaling of Output3 when it is used as a pulse output or current output.

If the Output3 function is for **pulse output**, 0 to 1000 Hz, the number of volume units per pulse is defined in Scale.

Example: The meter size (MeterSize is read in E1 at the PD 210 display unit) is 20000 litres per hour. The requirement is for 0.01 litres per pulse on Output3 (equal to 100 pulses per litre). The figure **0.01** is therefore inserted in **Scale** (E5 on PD 210).

In this example a flow of 20000 litres per hour will give an Output3 frequency of

$$\frac{20000\text{ l/h}}{0.01\text{ l/pulse} \times 3600\text{ sec/h}} = 555.5\text{ pulses/sec}$$

Note: Be sure that the frequency on the output does not exceed 1000 Hz.

If the Output3 function is for **current output**, 4 - 20 mA, Scale will indicate the full-scale value of the data for the current output.

Example: Full scale (20 mA) is required to be the current output at 15000 litres per hour. The number 15000 is inserted in Scale. 4 mA always equals a measured result of 0.

If the function of Output3 is a **PI-regulator**, Scale will indicate the proportional band of the regulator. The proportional band for a regulator is the change required in the input signal to give a change from 0 to 100% in the output signal (without I). The proportional band is defined in the same unit, as the input signal to the regulator - e.g. m³/h.

See also the application example [Flow control](#).

Please consult the specialist literature on the subject of process control for further information on how to set the regulator parameters for particular purposes.

E6, Display resolution

P-NET SWNo. 25: Code1

Various measurement results can be read out from the Flow Transmitter using the display unit. E6 is used to determine how many digits appear after the decimal point when displaying each of these values. The resolution may be in the range from 0 to 6.

The data type for E6 is a LongInteger, which may be considered as 8 digits in hexadecimal readout. The first 6 digits represent and select the resolution for one register. Digit 7 and 8 are not used and should be set to 0. The information must be interpreted as shown below (only digits 1 to 6 are applicable to the PD 210 display unit):

Digit 1	Digit 2	Digit 3	Digit 4	Digit 5	Digit 6	7	8
Flow	TCFlow	Volume1	Volume2	Setpoint	Instantflow		

For digit 3 - Volume1 and digit 4 - Volume2, the resolution also determines the maximum value for the counters, i.e. the overflow value [See also the description for Volume1](#).

Example: The size of the transmitter is 80 m³/h. Flow is requested on the display with a resolution of 0.01 m³/h. Set digit 1 in E6 equal to 2 (2 digits after the decimal point).

When the Output2 function is for pulse output, 0 - 10 Hz, the resolution on Volume1 indicates the resolution on the display read out as well as the pulse output. Output2 will give a pulse each time the least significant digit changes on the display.

Example: In MeterSize the size of the transmitter is specified to be 20 m³/h. On Output2, 1 pulse is required for each 0.01 m³ (10 litres). Digit 3 in E6 is set to 2 (2 digits after the decimal point).

At a flow of 20 m³/h, the frequency on Output2 is:

$$\frac{20 \text{ m}^3/\text{h}}{0.01 \text{ m}^3/\text{pulses} \times 3600 \text{ sec}/\text{h}} = 0.55 \text{ Hz}$$

Note: Resolution should be chosen so that the frequency on Output2 does not exceed 10 Hz.

**E7, Function selector****P-NET SWNo. 26: Code2**

The contents of E7 defines the functions of Output2, the functions and control data for Output3, data for volume counters, data for the batch control / limit switch and the operational mode for the Flow Transmitter.

The data type for E7 is a LongInteger, which may be considered as 8 digits in hexadecimal readout. The first 6 digits represent and select one of the above-mentioned options. Digits 7 and 8 are not used and should be set to 0. The information must be interpreted as shown below (only digits 1 to 6 are applicable to the PD 210 display unit):

Value	Dig. 1	Dig. 2	Dig. 3	Dig. 4	Dig. 5	Dig. 6	7	8
	Function Output3	Data for Output3	Function Output2	Data for vol counter	Mode	Data for batch/limit		
0	No function	No function	No function	No counting	Normal	No batch/limit	0	0
1	PI-regulator	Flow	Pulse output 0 - 10 Hz	Flow	Linearizing function enabled	Flow	0	0
2	Current output, 4-20 mA	TCFlow	Batch control	TCFlow		TCFlow	0	0
3		Temp				Temp	0	0
4	Pulse output, 0 - 1000 Hz	Available	Limit switch			Available	0	0
5						Volume1	0	0
6	3-phase output mode 1		Error code=0			Volume2	0	0
7	3-phase output mode 2						0	0
8	3-phase output mode 3	Instantflow	Sign for Output3	Instantflow	TEST	Instantflow	0	0

It is not possible to select the PI-regulator function for Output3 and Batch control or Limit switch for Output2 at the same time, because the Setpoint register is used for all three functions.

3-phase output mode is described in Chapter 7, *3-phased output signals*.

With Output2 function *Sign for Output3*, means Output2 is OFF for positive flow.

During TEST mode the flow is not calculated by the transmitter, and can thus be inserted in the Flow register, e.g. using the display unit.

See also the Flow control application example in the [Flow control](#) chapter for a specific configuration of the E7 register.

The *Limit switch function* is used to set an alarm on Output2: In case of an actual flow under a specified setpoint, Output2 will change its state from ON to OFF. Details in Chapter 2.3.3.

E8, Function selector

P-NET SWNo. 27: Code3

The contents of E8 defines the digital filter for Flow, selects the calculation of flow direction and temperature, defines the function for Input1 and holds the P-NET node address for the Flow Transmitter.

The data type for E8 is a LongInteger, which may be considered as 8 digits in hexadecimal readout. The first 6 digits represent and select one of the above-mentioned options. Digits 7 and 8 are not used and should be set to 0. The information must be interpreted as shown below (only digits 1 to 6 are applicable to the PD 210 display unit):

Value	Dig. 1	Dig. 2	Dig. 3	Dig. 4	Dig. 5	Dig. 6	7	8
	Flow unit Time const.	Calculation of flow	Calculation of temp.	Input1 function	P-NET node address			
0	Unit/min Time = 0.15 s	Unidirectional flow<0.2% =0			Two-digit number: 01..7D		0	0
1	Unit/hour Time = 0.15 s						0	0
2	Unit/min Time = 1.0 s	Unidirectional	Unit = °C	Stop counters => no error			0	0
3	Unit/hour Time = 1.0 s		Unit = °F	Stop counters => error = 05			0	0
4	Unit/min Time = 5.0 s	Bidirectional flow<0.2% =0		Clear Volume2 Start Batch			0	0
5	Unit/hour Time = 5.0 s						0	0
6	Unit/min Time = 10.0 s	Bidirectional					0	0
7	Unit/hour Time = 10.0 s						0	0

The positive flow direction is indicated by an arrow on the meterhead. When metering in both directions, flow in the direction of the arrow is registered as positive flow, and flow in the opposite direction of the arrow is registered as negative flow. When set to measure in one direction only, flow in the opposite direction to the arrow is ignored.

The P-NET node address is a two-digit number in the range from 01 to 7D in hexadecimal readout, where digit 5 is the most significant digit. When using the PD 210 display unit, only the digits from 0 to 9 can be used, and thus the highest possible node address is 79.

See also the [Batch control application example](#) for a specific configuration of the E8 register.



6.2 Factory settings

If specific functions are not requested at time of order, the transmitter will be delivered with the following factory settings. The digits 7 and 8 are set to zero. In the rest of the tables in the manual, these two digits are left out, as they are not accessible from the PD 210 Display.

PD 210 address Variable name	C 25	C 38	C 51	C 63	C 76	C 102	
E1 Meter Size	8.0	20.0	40.0	80.0	120.0	200.0	
E5 Scale	Standard	.000010	.000010	.000100	.000100	.000100	.000100
	Extended	8.00000	20.0000	40.0000	80.0000	120.000	200.000
E6 Display resolution	333333	333333	222222	222222	222222	222222	
E7 Function selector	Standard	411100	411100	411100	411100	411100	411100
	Extended	211100	211100	211100	211100	211100	211100
E8 Function selector	302411	302411	302411	302411	302411	302411	

Note that the E5 scale value for standard version in the table is keyed-in in m³ pr. pulse, due to the corresponding E1 setting in m³, whereas the resulting output below is expressed in litres pr. pulse.

The above factory settings result in the following outputs:

Standard version:

Output2: 1 litre/pulse (C 25 and C 38)
10 litres/pulse (C 51, C 63, C 76 and C 102)
Output3: 0.01 litre/pulse (C 25 and C 38)
0.1 litre/pulse (C 51, C 63, C 76 and C 102)

Extended version:

Output2: 1 litre/pulse (C25 and C38)
10 litres/pulse (C51, C63, C76 and C102)
Output3: 20 mA at max. flow rate

6.3 Changing settings

The specified settings for E1, E5, and E6 in Chapter 6.2 define as a whole that all readouts and values are in cubic metres, m³.

The values in E5 and E7 must always correspond to each other, depending on whether the configuration is for standard or extended use.

The following information applies to all examples in Chapter 6.3.

A flow transmitter delivered in standard version cannot have its settings changed to extended version functionality. Output3 can only be used for pulse output, and P-NET communication is not an option in this version.

A flow transmitter delivered in extended version, however, can have its settings changed to standard version functionality, if required. Output3 can be used for either pulse output, 3-phase output or 4-20 mA analogue output. P-NET communication is also an option in this version.

Refer to wiring diagrams and examples in this manual regarding how to apply Output2 for pulse, batch control, sign, etc., and for Output3 regarding pulse, 3-phase, or 4-20 mA analogue use.



Changing settings from m³ to litre measurements

If you wish to change your measurements from one unit to another, you should first of all pay attention to the value of E1, the size of the meter. Use the PD 210 display to read out the value by tapping “E” followed by “1”. Changing the value is done by keying in the new value and confirming with “=”. Additional changes must be carried out as well, depending on the application, as described on the previous page.

PD 210 address Variable name	C 25	C 38	C 51	C 63	C 76	C 102
E1 Meter Size	8000.0	20000.0	40000.0	80000.0	120000	200000
E5 Scale Pulse output	.010000	.010000	.100000	.100000	.100000	.100000
Output 3 Analogue output	8000.0	20000.0	40000.0	80000.0	120000	200000
E6 Display resolution	000000	000000	000000	000000	000000	000000
E7 Function Pulse output	411100	411100	411100	411100	411100	411100
selector Analogue output	211100	211100	211100	211100	211100	211100
E8 Function selector	302411	302411	302411	302411	302411	302411

The settings result in the following outputs and flow limitations:

Pulse and pulse output:

Output2: 1 litre/pulse (max. flow 8,000 l/h for C 25 and 20,000 l/h for C 38)
 1 litre/pulse (max. flow 36,000 l/h for C 51, C 63, C 76 and C 102)

Output3: 0.01 litre/pulse (C 25 and C 38)
 0.1 litre/pulse (C 51, C 63, C 76 and C 102)

Pulse and analogue output:

Output2: 1 litre/pulse (max. flow 8,000 l/h for C 25 and 20,000 l/h for C 38)
 1 litre/pulse (max. flow 36,000 l/h for C 51, C 63, C 76 and C 102)

Output3: 20 mA at max. flow rate

The reason for the flow limitations for flow transmitter sizes C 51 through C 102 is that measuring in litres leads to a signal on Output2 for each single litre. Thus litre measurement setting is a bad solution, if the intention is to use Output2 for pulses.

7 3-phase output signals

The PD 340 Flow Transmitter in extended version can be configured to drive 3-phased output signals. The configuration makes the Flow Transmitter act like a mechanical flowmeter.

The 3-phase output signals may be used in three different modes. Below is a brief overview prior to more comprehensive explanations later in this chapter:

- Three-phase counter without separate error signal.
- Two-phase counter with separate error signal.
- Counter with up/down signal and separate error signal.

When used for one of the 3-phase output modes, the output signals and the matching options CANNOT be configured or used as described in the previous chapters, and the texts on the terminal board lose their original meaning as well.

Instead, the outputs are used as shown in the drawing below. It is universal for all the 3-phase application modes, in terms of the electrical connections for the signals, i.e. Signal 1, Signal 2, Signal 3, respectively.

The operation mode is selected by means of E7, digit 1. Please refer to the table at the end of this chapter for an overview of the relationship between modes and their corresponding signals and terminal numbers.

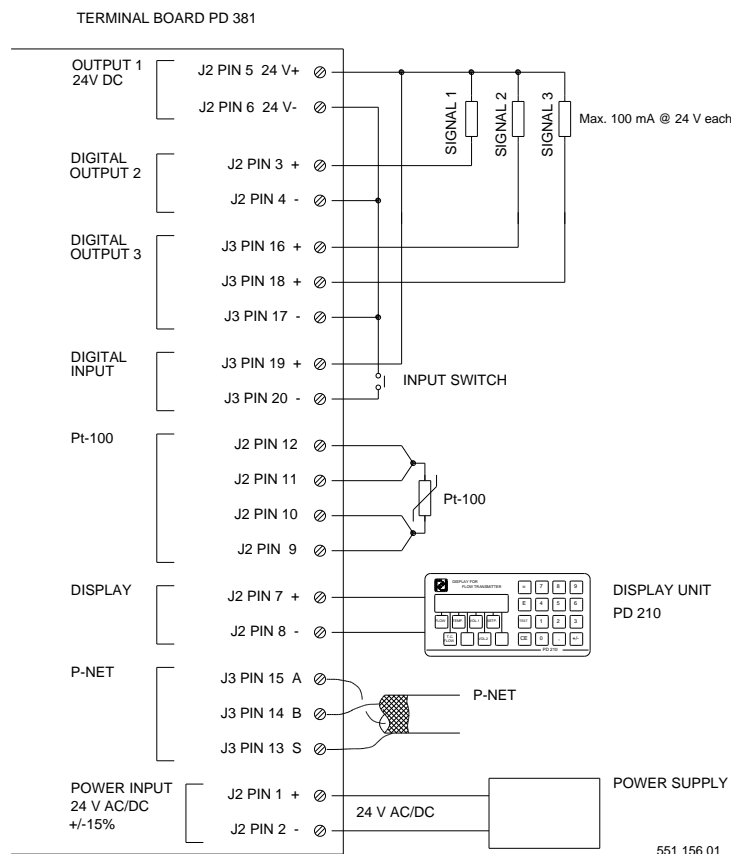



7.1 3-phase counter without separate error signal (mode 3)

This mode indicates the flow rate by means of 3-phase pulse signals. The phase sequence indicates the flow direction and the pulse frequency indicates the flow rate. An error in the Flow Transmitter will open the three output signals (high-impedance state). See the first of the signal diagrams below. In the second diagram, backward flow alters the sequence of the output signals. Apart from the phase sequence, the functionality for backward flow is the same as for forward flow.

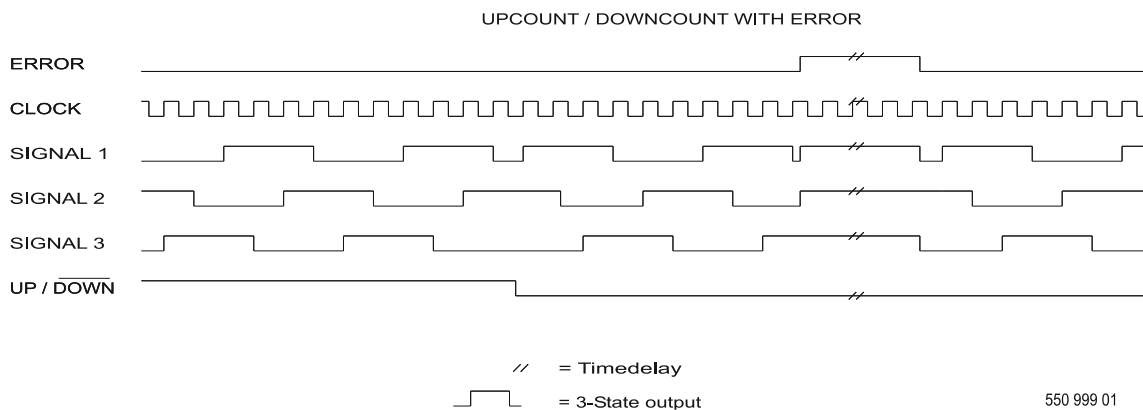
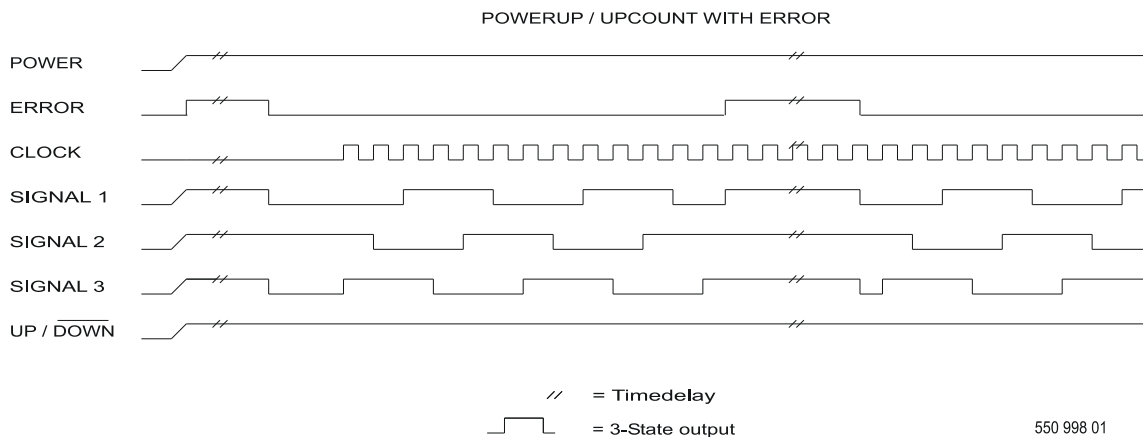

7.2 2-phase counter with separate error signal (mode 2)

This mode indicates the flow rate by means of 2-phase pulse signals. The error signal is closed circuit during error-free measurement. The phase sequence indicates the flow direction and the pulse frequency indicates the flow rate. An error in the Flow Transmitter will open the three output signals (high-impedance state), i.e. the error signal and both pulse signals. See the first of the signal diagrams below. In the second diagram, a backward flow alters the sequence of the two pulse signals. Apart from the phase sequence, the functionality for backward flow is the same as for forward flow.

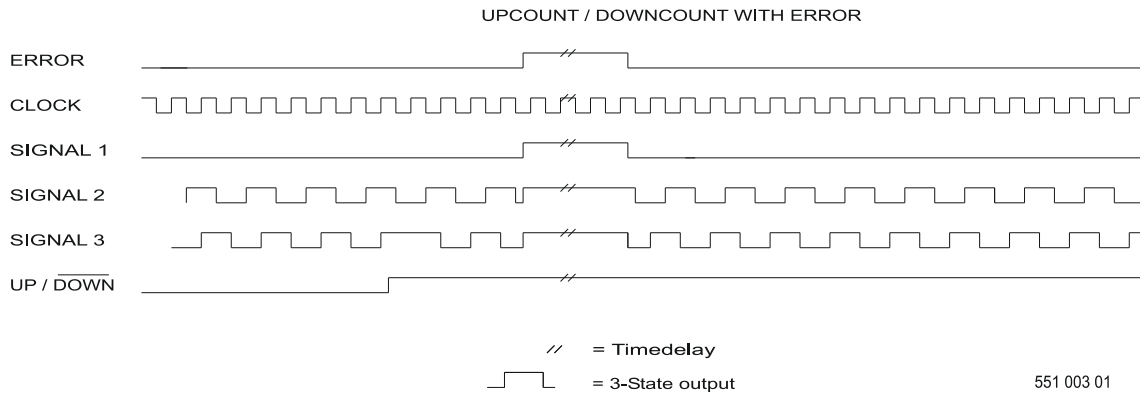
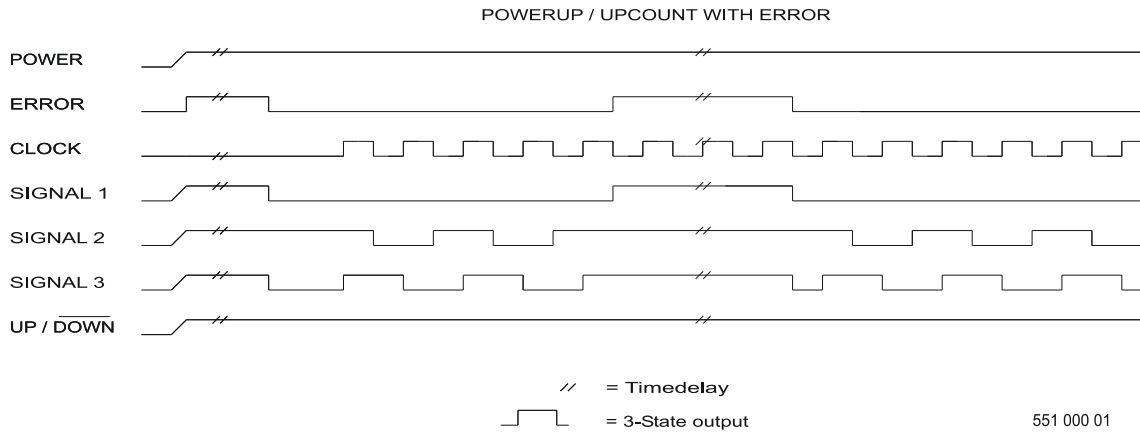

7.3 Counter with up/down signal & separate error signal (mode 1)

This mode indicates the flow rate by means of 1 pulse signal. The error signal is closed circuit during error-free measurement. The flow direction is indicated by the up/down signal and the pulse frequency indicates the flow rate. An error in the Flow Transmitter will open all 3 output signals (high-impedance state). See the signal diagram below.

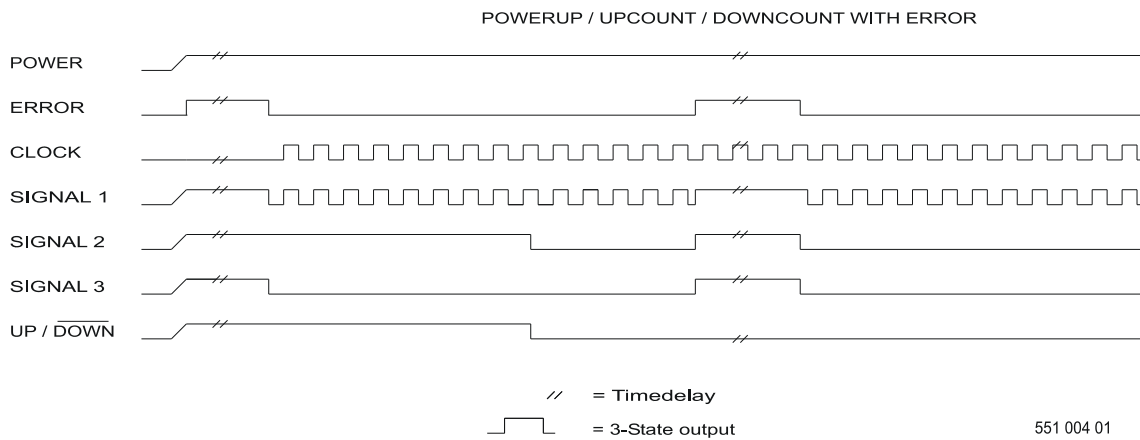



7.4 Table showing signal mode relationships

The table shows the function of each signal, depending on the selected mode.

	Mode 1 simple	Mode 2 2-phase	Mode 3 3-phase	Terminal number
E7 digit 1	6	7	8	
Signal 1	Phase 1	Error	Phase 1	3
Signal 2	Up/down	Phase 1	Phase 2	16
Signal 3	Error	Phase 2	Phase 3	18

The configuration for the Flow Transmitter should adhere to the following example when utilising the 3-phased output mode.

Examples with configuration settings for 3-phase output:

PD 210 address Variable name	C 25	C 38	C 51	C 63	C 76	C 102
E1 Meter size	8.0	20.0	40.0	80.0	120.0	200.0
E5 Scale 3-phase output	.01667	.01667	.01667	.01667	.01667	.01667
E6 Display resolution	333333	333333	222222	222222	222222	222222
E7 Function selector	Mode 1	618100	618100	618100	618100	618100
	Mode 2	718100	718100	718100	718100	718100
	Mode 3	818100	818100	818100	818100	818100
E8 Function selector	302411	302411	302411	302411	302411	302411

8 Applications

8.1 Flow Control

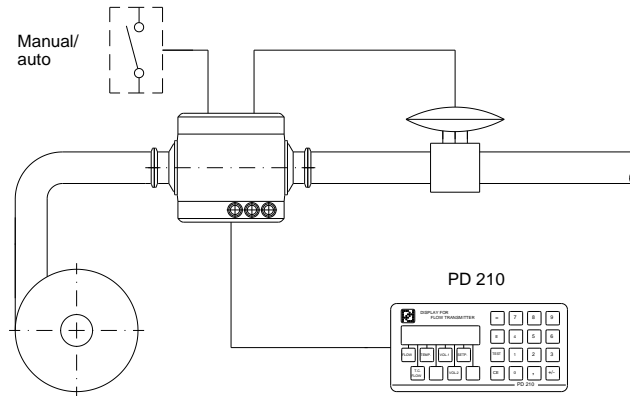

551 114 01

A centrifugal pump, a PD 340 Flow Transmitter, and a modulating valve with an I/P converter can form an accurate FLOW CONTROL SYSTEM. Alternatively, the pump can be controlled by a frequency converter.

The PD 340 Flow Transmitter has a built-in PI-REGULATOR, which can be operated in AUTO as well as in MANUAL. Input1 is used for this manual/auto selection.

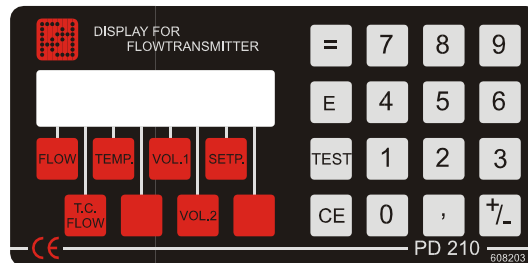

490 273 02

The requested flow rate is keyed into SETPOINT on the connected PD 210 display. The output value can be read in % by pressing the untitled key to the left of VOL.2. If the regulator is in MANUAL, the operator can key the requested output position into the same register.

Programming

To enable the PI REGULATOR function in the PD 340, the Flow Transmitter can be programmed as in the following table, taking into consideration issues like read-out format, etc. The program enable switch must be in position ON during programming.



Examples with configuration settings for PI-regulator output:

PD 210 address Variable name	C 25	C 38	C 51	C 63	C 76	C 102
E1 Meter Size	8.0	20.0	40.0	80.0	120.0	200.0
E2 Integration time Ti (typical)	2.0	2.0	2.0	2.0	2.0	2.0
E3 PI-regulator function	0000XY	0000XY	0000XY	0000XY	0000XY	0000XY
E5 Scale P-Band (typical)	2.0	5.0	10.0	20.0	30.0	50.0
E6 Display resolution	333333	333333	222222	222222	222222	222222
E7 Function select. PI-regulator	181100	181100	181100	181100	181100	181100
E8 Function selector	302411	302411	302411	302411	302411	302411

The P-band indicates the proportional sensitivity in the same flow units as the "FLOW" register (l/h or gallons/min.). The P-band is equal to the change in flow rate, which will change the output from 0 to 100%. A typical setting of E5 is 25 % of max. flow.

The Ti is the regulator's integration time in seconds. Ti is equal to the time the integrating part of the regulator requires to provide the same change on the output as the proportional part for a step in flow rate. A typical Ti time is 2 sec. The P-band and the Ti can be optimized by experiment, or by following the rules available in specialized literature.

Digit 5 in E3 (marked with an X) is set to 0 if the valve is normally closed at 4 mA, or set to 2 if the valve is normally open at 4 mA.

Digit 6 in E3 (marked with a Y) determines the function of the AUTO/MAN. Digit 6 = 0: The regulator is always in auto. Digit 6 = 1: The regulator is always in manual. Digit 6 = 2: If Input1 is ON, the regulator is in manual, otherwise in auto.

Refer to Chapter 6, E3 PI-regulator function for a detailed table with all combinations.

The P-band, Ti and Setpoint can always be changed, because these registers are stored in RAM. The contents will disappear after a power-cut, unless the programme enable switch is in position ON. In this case the contents of P-band, Ti and Setpoint are stored in EEPROM, and restored in RAM after power-up. The program enable switch must be switched off after programming, to preserve the EEPROM memory.

Electrical connections for a PI-regulator application

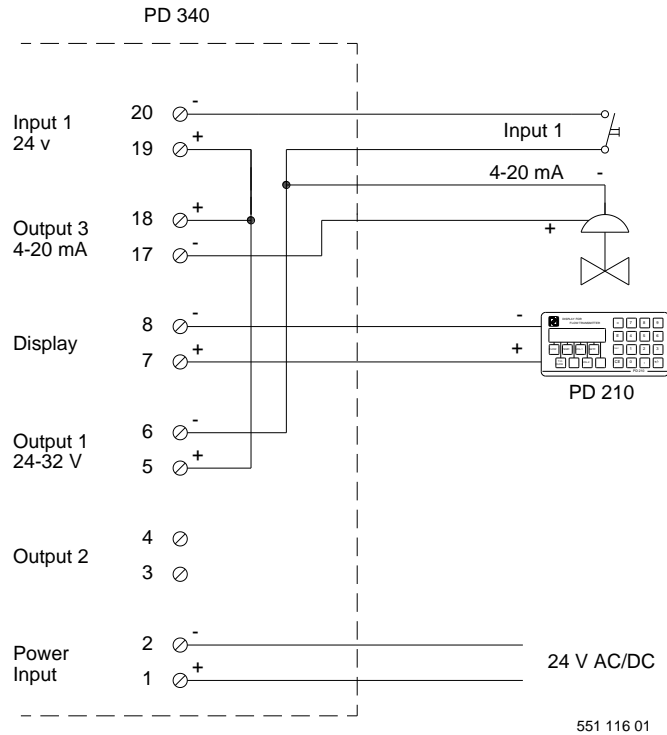

It is very important to select the correct valve size. Which size to choose depends on the following information: The min. and max. flow rate, the flow/pressure curves of the pump, and the pressure drop in the pipe work at the specified flow rate. It is normally recommended to ask the supplier of the modulating valve to select the size.

Note: It is not possible to select the PI-regulator function for Output3 and Batch control or Limit switch for Output2 at the same time, because the Setpoint register is used for all three functions.

8.2 Batch control using the PD 210 display

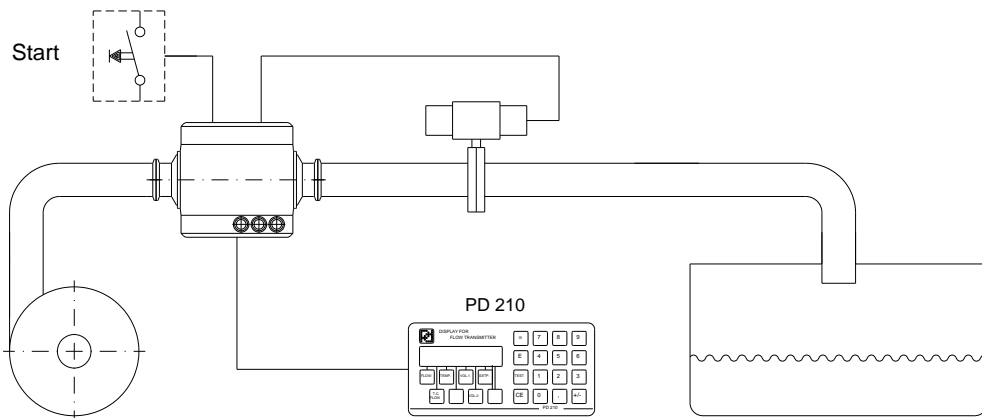

551 117 01



The PD 340 Flow Transmitter has a built-in batch control function, and can therefore be easily used to control the dosing of a specified volume. The requested volume is keyed into "SETPOINT" on the PD 210. Input1 on the PD 340 is used to start the batch control. Output2 controls the dosing valve or pump. The Volume2 counter shows the dosed volume. When the batch control function is used, the built-in flow regulator cannot be used.

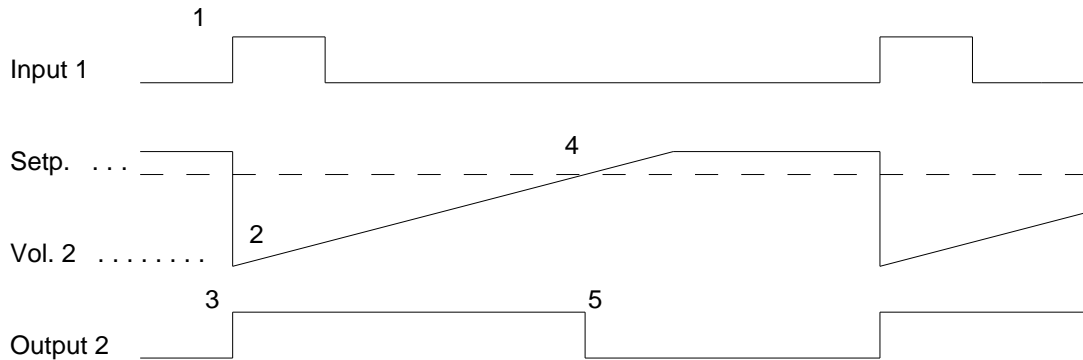

551 118 01

The function of the system

First, the requested volume is keyed into "SETPOINT". The dosing will start when Input1 is activated. This will clear the Volume2 counter and Output2 switches on. The valve or pump controlling the flow must be activated by the relay. When the liquid starts to flow, "Volume2" will count up, and when it is equal to the setpoint, Output2 will switch off. Because of the reaction time of the valve or pump, the flow will not stop immediately after Output2 is switched off. Consequently the actual dosed volume is a little higher than the setpoint. This after-flow is fairly constant if the reaction time and the flow rate are constant, and therefore it is possible to compensate for that by reducing the setpoint with the volume of the after-flow. The volume of this after-flow can be calculated as [Volume2 - setpoint].

Programming the batch control

To enable the batch control function in the PD 340, the Flow Transmitter can be programmed as in the following table, taking into consideration issues like read-out format, signal type for Output3, etc. The program enable switch must be in position ON during programming.

Examples with configuration settings for batch control:

PD 210 address Variable name		C 25	C 38	C 51	C 63	C 76	C 102
E1 Meter Size		8.0	20.0	40.0	80.0	120.0	200.0
E6 Display resolution		333333	333333	222222	222222	222222	222222
E7 Function selector	Batch	412106	412106	412106	412106	412106	412106
E8 Function selector	Batch	302411	302411	302411	302411	302411	302411

When programming is complete, the Program Enable Switch should be switched back to the OFF position. The value in the Setpoint register before the program enable switch was switched off will be used as a power-up value following a power-cut.

Note: It is not possible to select the PI-regulator function for Output3 and Batch control or Limit switch for Output2 at the same time, because the Setpoint register is used for all three functions.

Electrical connections for a batch control application

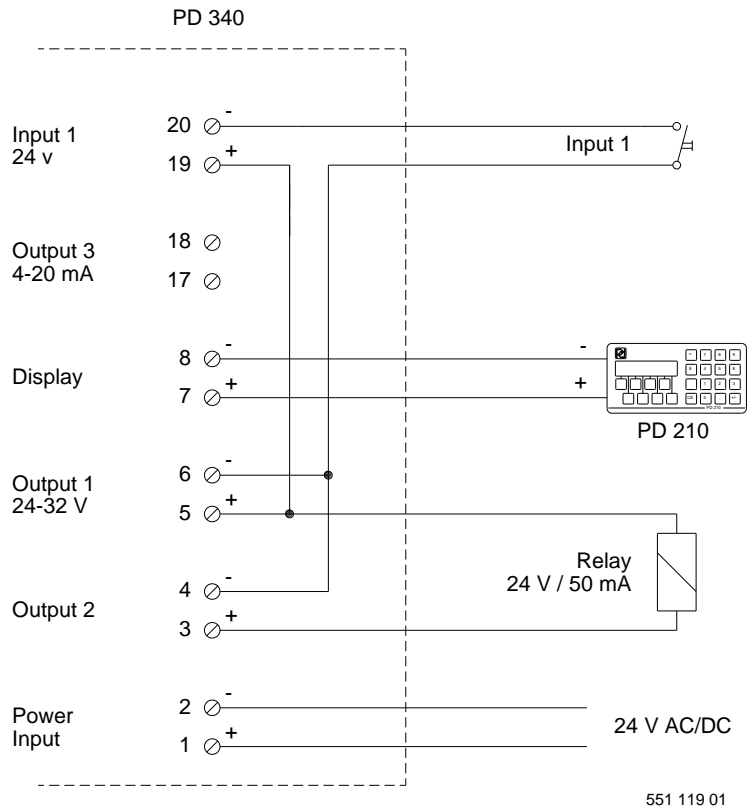



9 Fault finding

9.1 Error detection

The PD 340 Flow Transmitter is equipped with a comprehensive self-testing system, which is able to indicate faults arising from improper use of the transmitter, or faults arising whilst the transmitter is in use.

When the internal test system registers a fault, an error code, in the form of a number, is generated within the Flow Transmitter. If several errors in the error checking system should develop at the same time, only the highest numbered error is saved.

The error may be observed in different ways.

PD 210 display unit

The user is informed by an "A" for ALARM appearing in the first digit of the display. By pressing the "TEST" button, the display will show an error code of two digits, indicating the type of error. The test system ensures that the alarm will not be cancelled before the error code has been displayed by pressing the "TEST" button, even though the error may have disappeared. By pressing the "TEST" button once again, the display will show "0" if the Flow Transmitter is currently error free. The error code on the display is **only** updated by re-pressing the "TEST" button.

P-NET

If an error occurs, any reply from the Flow Transmitter will include an error indication, as long as an error code remains present. The error code is cleared by reading the Error3 register.

9.2 Typical errors

9.2.1 Flow Transmitter with PD 210 display unit

If neither the transmitter nor the display unit functions

- Check that the light-emitting diode in the terminal box is on.
- Check that the transmitter is correctly connected.
- Check that the supply voltage **at the Flow Transmitter** is at least 20 V AC or DC, when the transmitter is powered up (with the terminal box mounted on the transmitter).

If the display unit does not function

- Check that the cable between the transmitter and the display unit is correctly connected at both ends.
- Check that the cable is not defective.
- Check that the cable is not too long or too thin (max. 100 m, min. 0.75 mm²).

If external equipment, e.g. an electronic counter, does not function, or does not function properly

- Check that the equipment is correctly connected.
- Check that the transmitter data is being displayed correctly (e.g. using the PD 210).
- Check that the required functions for the output signals have been correctly set, and that the meter size is correct (e.g. using the PD 210).

If the transmitter does not indicate flow

- Check that there really is flow through the metering pipe.
- Check that the flow direction is correct.

If the transmitter gives a false read-out

- Check if there is any air in the liquid.
- Check that the conductivity of the liquid lies within the specified range.

9.2.2 Flow Transmitter without display unit

If the transmitter does not function

- Check that the light-emitting diode in the terminal box is on.
- Check that the transmitter is correctly connected.
- Check that the supply voltage **at the transmitter** is at least 20 V AC or DC, when the transmitter is powered up (with the terminal box mounted on the transmitter).
- Check that there really is flow through the metering pipe.
- Check that the flow direction is correct.

If the transmitter gives a false read-out

- Check if there is any air in the liquid.
- Check that the conductivity of the liquid lies within the specified range.



10 List of spare parts

The following spare parts are available for PD 340.

Meterhead without electronic module and terminal box:

- PD 340 C 25
- PD 340 C 38
- PD 340 C 51
- PD 340 C 63
- PD 340 C 76
- PD 340 C 102 (integrated electronic module)

Electronic module complete (not available for C 102):

- Standard version, 2-pulse output.
- Extended version, 1 current output, 1 pulse output, 3-phase pulse output, P-NET interface.

Terminal box

The Terminal Box contains clearly marked terminals for all inputs and outputs. The box is equipped with 3 cable glands, PG 11.

Clamp set for:

- C 25
- C 38
- C 51
- C 63
- C 76
- C 102

The clamp set consists of:

- 2 pcs. clamp rings (AISI 304)
- 2 pcs. clamp liners (AISI 316)
- 2 pcs. gaskets for above (NBR, Nitrile Rubber).

11 Specifications

All electrical characteristics are valid at an ambient temperature from -10 °C to +50 °C, unless otherwise stated.

All specifications apply within approved EMI conditions. EMC test specifications for the PD 340 are available in a separate document, PD no. **506 023**.

11.1 Flow measurement

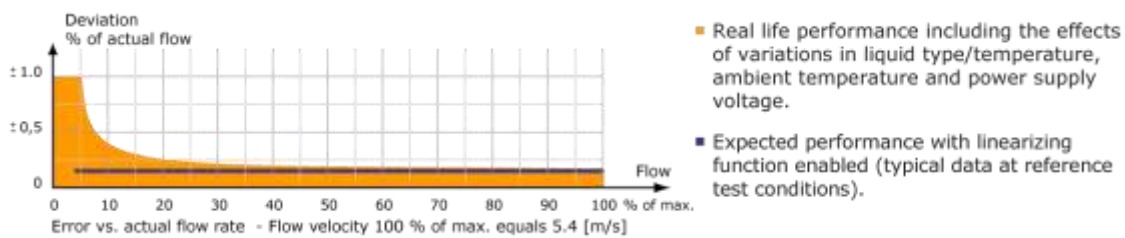

Figure 7: Max. error vs. actual flow rate

With the linearization function enabled, the accuracy at very low flow rates is improved considerably. See details in Chapter 1.6.

Flow measurement error:	typ. less than half the value as shown on Figure 7
Current output error:	As Figure 7, plus ± 0.3 % of current output range
Linearity:	(see Figure 7)
Repeatability:	max. (0.5 x error), (see Figure 7)
Ambient temperature effect:	max. 0.04 % / 10 °C
Voltage supply effect:	max. 0.01 % / 10%
Response time pulse output:	0.2 sec.
Response time current output:	0.1 sec.

11.2 Power Supply

The transmitter should always have the supply connected to prevent condensation in the electronics.

Power supply AC (50/60 Hz) or DC:	nom.	24.0 V
	min.	20.0 V
	max.	28.0 V
Current at power up:	max.	650 mA
Fuse (time lag):		0.8 A
Power consumption:	max.	6 W

11.3 Liquid

Conductivity:	min.	5 μ S/cm
---------------	------	--------------



Temperature range:	-30 °C to +100 °C
Pressure:	max. 10 bar
Pressure test:	max. 15 bar

11.4 Measurement of temperature

Temperature input with Pt100 sensor (IEC 751, DIN 43760). Specifications exclude the accuracy of the Pt100 sensor.

Range:	-30 °C to +100 °C
Error:	max. ± 0.9 °C

11.5 Environment

Ambient temperature:	-10 °C to +50 °C
Protection:	IP 67

11.6 Approvals

Compliance with EMC-directive no.:	89/336/ECC
Generic standards for emission:	
Residential, commercial and light industry	DS/EN 61000-6-3
Industry	DS/EN 61000-6-4
Generic standards for immunity:	
Residential, commercial and light industry	DS/EN 61000-6-1
Industry	DS/EN 61000-6-2

11.7 Dimensions and capacities

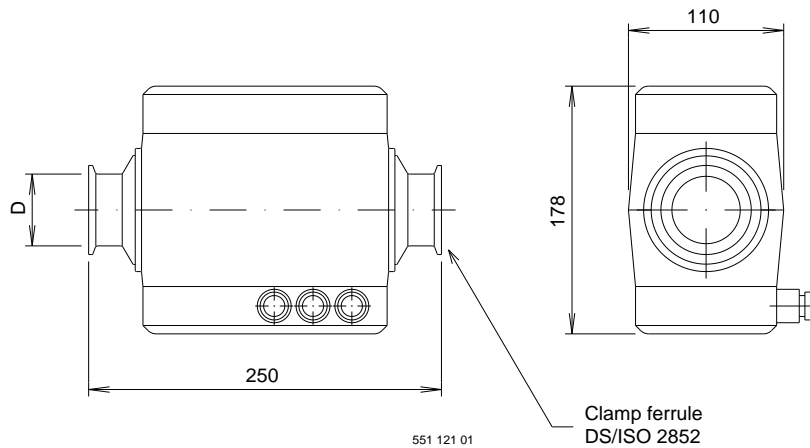

Figure 8: Dimensions (C 25 through C 76)

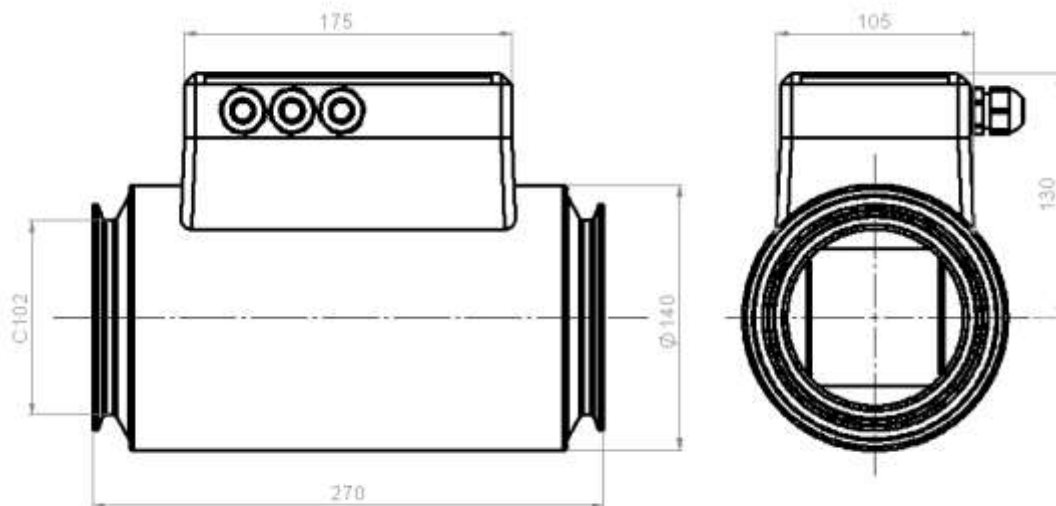

Figure 9: Dimensions (C 102)

11.8 Maximum flow rates and weight

Meter size	Nom. size D i mm	Max. flow rate m ³ /h	Weight in kg
C 25	25	8	5
C 38	38	20	5
C 51	51	40	5
C 63	63.5	80	5
C 76	76	120	5
C 102	102	200	10.5

Note: The max. flow rate for the Flow Transmitter must NEVER be exceeded. Otherwise the meterhead may be damaged.



11.9 Material

Electrodes:	Stainless steel AISI 316.
Metering pipe:	Stainless steel AISI 316.
Coating inside metering pipe:	PFA.
Housing:	
C 25 – C 76:	PPO Noryle.
C 102:	Stainless steel AISI 316.

11.10 Connections

Clamp pipe coupling DS/ISO 2852.

12 Appendix 1

12.1 Memory types

The PD 340 stores data in different types of memory depending on the value of a control variable following a reset or a power failure, and the state of the write protection.

Some variables are stored in both non-volatile memory and in volatile memory. The state of the module's Program enable switch determines whether the contents are changed in both types of memory or only in the volatile type.

The following memory types are listed in the channel definition tables.

Read Only

PROM ReadOnly

The PROM is always write protected and can never be changed.

RAM ReadOnly

The variable is stored in RAM and is only accessible for Reading.

Read Protected Write

EEPROM RPW (Read, Protected Write)

By setting the ProgramEnable switch to ON, the contents of the EEPROM can be changed. The contents of the EEPROM will remain unchanged during and after a power failure.

Read Write

RAM ReadWrite

The variable can be changed instantly. After reset or a power failure, its value is set to zero.

Read Write, Protected BackUp Write

RAM InitEEPROM

The variable is stored in both RAM and EEPROM. After a reset, the variable is copied from EEPROM into RAM. When the variable is changed, the value is changed in RAM. If the ProgramEnable switch is ON, the value is changed in both RAM and EEPROM when the variable is changed.



13 Appendix 2

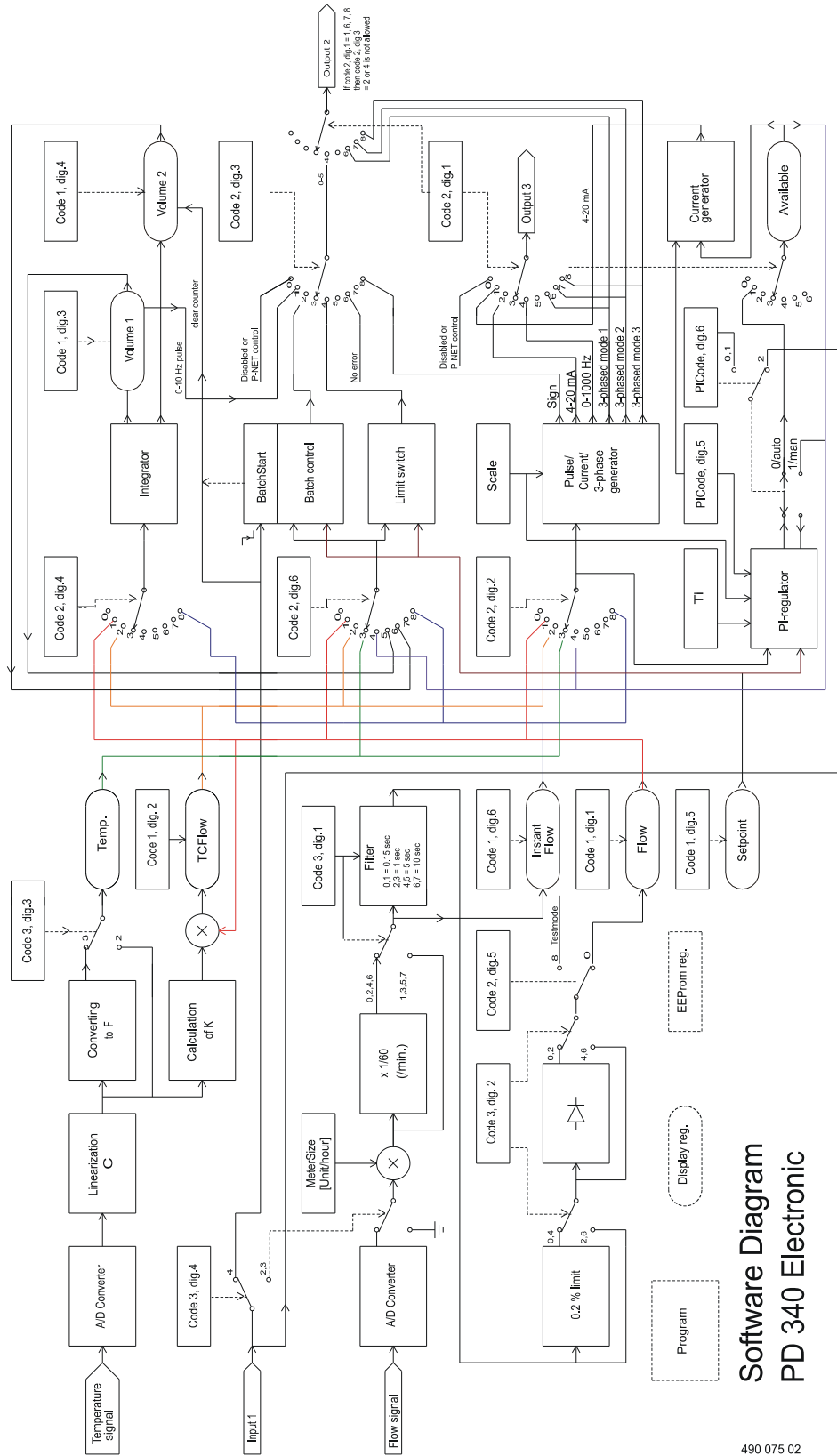

Software Diagram
PD 340 Electronic

490 075 02

Figure 10: Software diagram