

Flow Transmitter PD 340 Series

High Precision
Flow Transmitter
for Sanitary applications



PROCES-DATA A/S

Introduction

Flow Transmitter PD 340 Series

The PD 340 Flow Transmitter is an electromagnetic precision meter for the volumetric measurement of liquids that are electrically conductive. The transmitter can be used in applications where a hygienic design is required. The rugged construction of the transmitter makes it suitable for installations where solid particles are present in the liquid.

Advantages

- Suitable for sanitary applications - Designed especially for the food industry.
- No moving parts - No maintenance.
- Robust and compact design - Easy to mount, even in difficult applications.
- Factory configured to suit customer requirements - Makes installation easy and saves time and money.
- Constructed to be independent of variations in flow profile - High accuracy, even if the viscosity or the liquid changes. Change between different media, such as milk, cream, and liquids containing solids, without any need for recalibration.
- Optimised for high accuracy and linearity. Using the linearising function, it is possible to measure within a 1:100 turn down range. Therefore, the meter can normally be chosen to have the same size as the diameter of the pipe work, and the cost of installation and any pressure drop can be minimised.
- Volumetric measurement in m³, litres, U.S. gallons etc.

Functions

- Pulse and 4-20 mA outputs.
- Batch control function.
- Built-in PI flow controller.
- Simple display connection. (PD 210)
- **P-NET** IEC 61158 Fieldbus communication.
- Two built-in counters for totalising the volume flow.
- Inputs for temperature sensor and digital signal.

Specifications

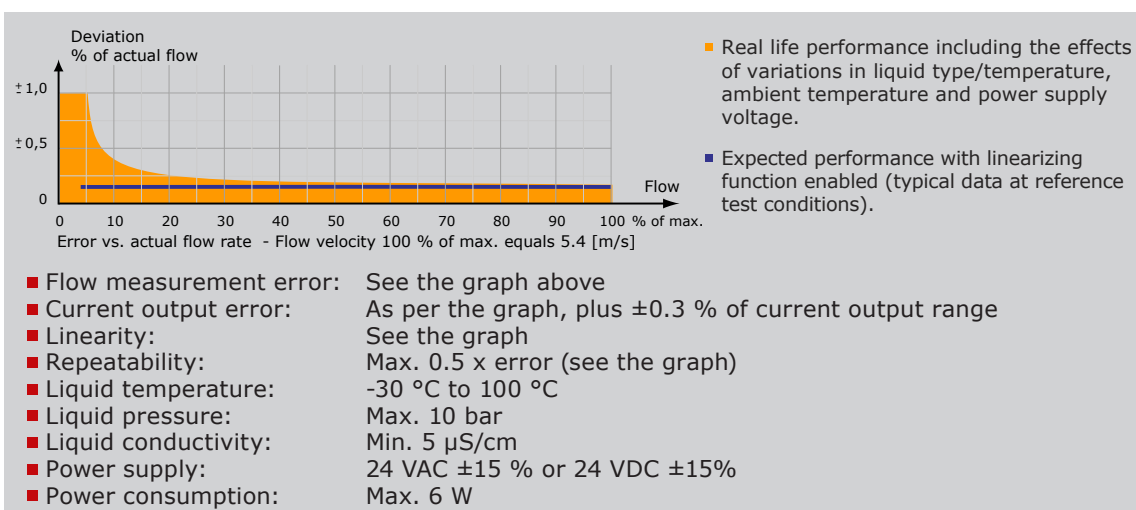

Approvals

- MID 2004/22/EC - Evaluation Certificate number TC7204).

Selection guide

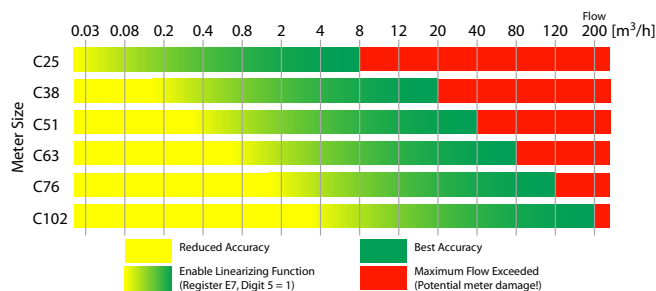

When selecting the meter size, use the diagram to the left and observe the following guidelines:

- Flow Transmitter with a pipe dimension equal to the rest of the piping system should be selected.
- If optimum measurement accuracy is of primary concern, the smallest possible transmitter should be chosen, while still observing that the maximum flow rate must never be exceeded.

Mechanical

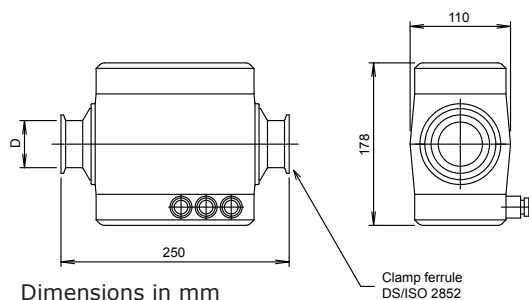

Meter size	Nom. size D in mm	Max. flow m ³ /h	Weight in kg
C25	25	8	5
C38	38	20	5
C51	51	40	5
C63	63	80	5
C76	76	120	5
*C102	102	200	10.5

(* Other mechanical dimension)



PROCES-DATA

Navervej 8-10 • 8600 Silkeborg • Denmark
Tel.: +45 87 200 300 • www.proces-data.com